

# Unimoulder

Unimoulder shaping your dough, designed and produced by **Benier**

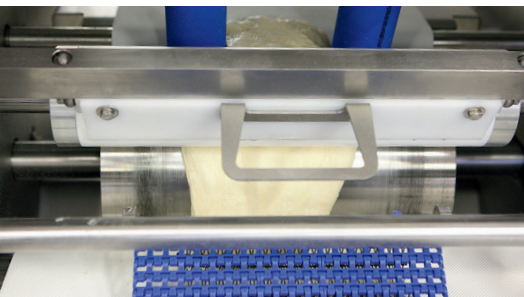

Moulding Drum

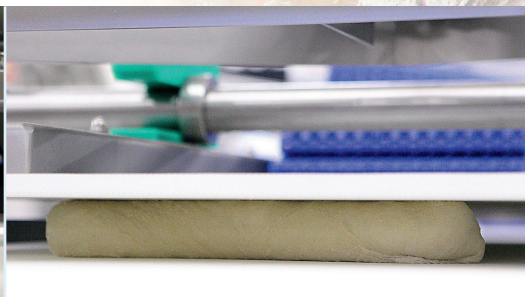

Pressure board



Adjustable sheet thickness



## Advantages

- **Dynamic infeed rollers for:**
  - Perfect centring of dough
  - Optimizing dough supply to moulding roller
- **Moulding performance adjustable to the dough consistency**
  - Pressure of roller to the dough
  - Opening for moulding defines thickness of sheet
  - Speed of process
- **Quick release concept**
  - Easily exchangeable lengthening board
- **Compact design and easy access for cleaning**

## ASIAN product range



Divider DAM BD 24



Rounder - Allround

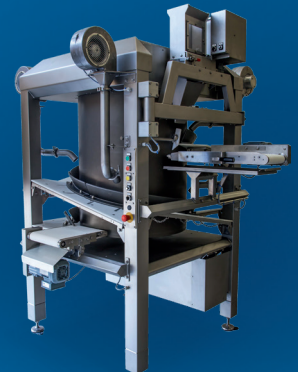

Unirounder

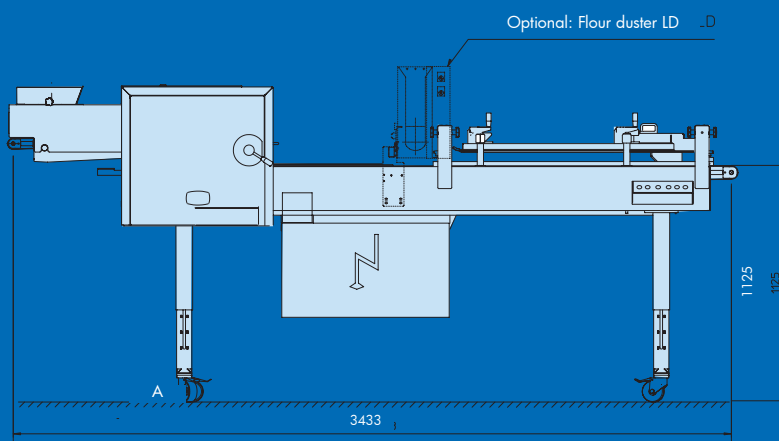

## Specifications Unimoulder

Weigh range (gr)		Capacity (pcs/hr)
Min.	Max.	
30	200	> 6.000
200	400	> 4.000
400	600	> 3.000
600	1.000	> 2.500

Maximum length 450 mm