



# CAKE DONUT DEPOSITORS

Type 'B' • Type 'F' • Type 'N' • Donut Robot®

Belshaw's Donut Depositors, the industry standard for over 75 years, are legendary for their precision and smoothness of operation - even after years of use in harsh conditions.

Each Donut Depositor is engineered of durable gears, cams and trip arms that ensure identical volume and shape are produced with each and every deposit. Large swing arms enable precise positioning above the fryer with almost no effort. All units are mountable on a circular column or directly onto a wall.

Belshaw **Type 'B'** Donut Depositor is a mechanically assisted, hand crank machine designed for open kettle fryers of any make/model. The Type 'B' holds 15 lbs (7 kg) batter weight, and accepts all 10 Belshaw donut plungers and attachments, each forming one or more cake donut varieties. A typical operator can deposit 60 to 100 donuts per minute.

Belshaw **Type 'F'** Donut Depositor is equivalent in size to the Type 'B', but utilizes a motor and touch-sensitive handle to deposit at a rate up to 115 strokes per minute. The faster stroke rate and easier operation of the Type 'F' reduces frying time variability between the first and last donuts dropped into the fryer, particularly for large fryers such as the Belshaw 724 and 734 fryers, and is physically easier on the operator. The "Deluxe" option features a highly polished aluminum body.

Belshaw **Type 'N'** Donut Depositor holds 12 lbs (5 kg) batter weight and is used with smaller fryers such as Belshaw's 616 tabletop fryer. The **Automatic Type 'N'** is designated for use with Belshaw Mark IX Donut Robot® fryers only. Type 'N' accepts the same plunger varieties as Types 'B' and 'F', but with shorter shaft length.

All Donut Robots® employ an automatic cake donut depositing system that only requires filling with batter. The **Donut Robot® Automatic Depositor** operates with its own set of plungers and attachments for forming plain, star, french cake, mini, ball, nugget, dunkerette, and crescent donuts.<sup>1</sup>

### Notes

<sup>1</sup> Suitable for Mark I, Mark II and Mark V. For Donut Robot® Mark VI, choose **either** the Donut Robot automatic depositor **or** the Type 'F' depositor.



Belshaw Type 'B'



Belshaw Type 'F'



Type 'F' Deluxe



Belshaw Type 'N'

### DONUT ROBOT® AUTOMATIC DEPOSITORS



Left: Donut Robot® Standard depositor



Right: Automatic Type 'N' depositor (for Mark IX only)

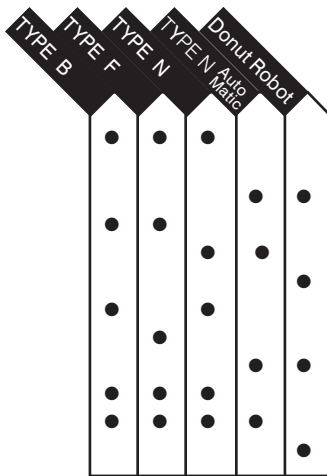

## Product Information

Aluminum alloy frame and arm assembly, hardened steel cams, bronze trip arms and bushings, aluminum hopper  
 Stainless steel and aluminum cutter unit, aluminum hopper<sup>1</sup>  
 15 lb/7 kg capacity hopper  
 12 lb/5 kg capacity hopper  
 10 lb/4.5 kg capacity hopper  
 Hand crank operation  
 Motorized crank, controlled by hand trigger  
 Motorized, synchronized with fryer  
 Wall mounting or column mounting available  
 Compatible with Type B, F & N plungers and cylinders<sup>1</sup>  
 Compatible with Donut Robot® plungers<sup>2</sup>

### Notes

- 1 Cylinder and plungers ordered separately. See plungers section of product guide.
- 2 Plain 1 9/16in plunger supplied standard. See Cake Donut Plungers section of equipment guide for details of plungers and attachments

### Type B Depositor

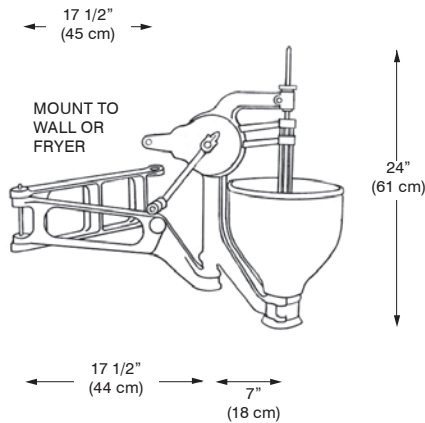

### Type F Depositor

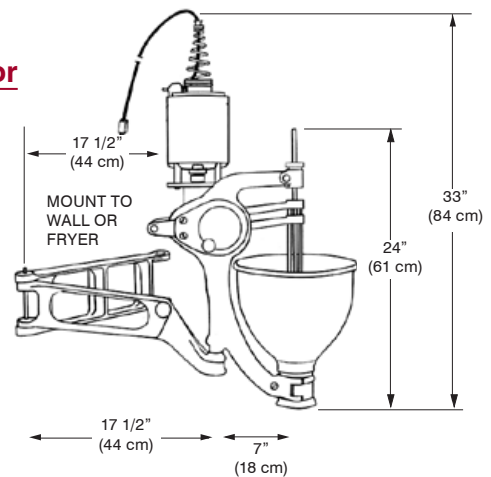

### Type N Depositor (Standard)

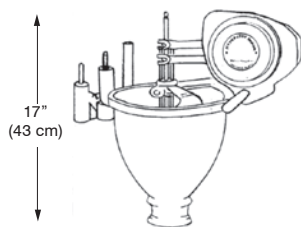

### Type N Depositor (Automatic)

For certifications, see Automatic Fryers section of the Equipment Guide.

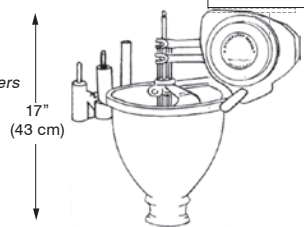

### Donut Robot® Depositor

For certifications, see Automatic Fryers section of the Equipment Guide.

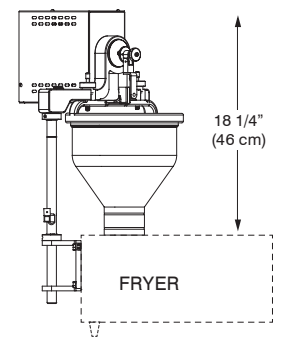

## Dimensions And Power

MODEL	SHIPPING WEIGHT		HOPPER CAPACITY		MAX OUTPUT	ELECTRICAL					
	Shipping Class = 85		lbs.	kg.		120V,60Hz,1ph		120V,50Hz,1ph		240V,50/60Hz,1ph	
	Depositor only	Depositor+mount			W	A	W	A	W	A	
Type B	30 lbs (14 kg)	48 lbs (22 kg)	15	7	100						
Type F	40 lbs (18 kg)	67 lbs (31kg)	15	7	115	570W	4.9	495W	4.5	510W	2.3
Type N	25 lbs (11 kg)	32 lbs (15 kg)	12	5	100						
Type N Automatic		45 lbs (21 kg)	12	5	n/a	480W	4.1	480W	4.1	480W	2.1
Donut Robot Mark II - IX		36 lbs (16 kg)	10	4.5	n/a	250W	2.2	240W	2.1	240W	1.1