

SD-600 Dough Divider

A 22 litre oil tank equipped with level detectors. First level: acoustic signal warning. Second level: acoustic signal with machine stop.



Stepless adjustable pneumatic system for very gentle handling of different types of dough. Can be adjusted during production.



Intuitive and user-friendly touch screen, including storage of recipes and countdown of the batch size in both quantity and time. Selected sections of the user manual and service reports can be viewed as well.



Quick release on outfeed conveyor to facilitate cleaning.

Accessories

Hopper 225 litre	Dough Hopper 225 lit, approximately 150 kg dough (Standard is 100 lit 70 kg dough)
Flour duster, mechanical	Flour duster on the first conveyor, mechanical
Non-stick coating of hopper 100L	Interior of the dough hopper 100L non-stick to assure a smooth infeed of the dough
Non-stick coating of hopper 225L	Interior of the dough hopper 225L non-stick to assure a smooth infeed of the dough
Hopper lubrication for 225 litre hopper	Automatic lubrication inside the dough hopper, by means of a spread tube system
Special belt	Special customized belt on one or both conveyors

Technical data

Capacity range	
2-pocket	1000 - 3000 dough pieces/hour
3-pocket	1500 - 4500 dough pieces/hour
4-pocket	2000 - 6000 dough pieces/hour
Weight range	
2-pocket	250 - 1700 gram
3-pocket	150 - 1000 gram
4-pocket	100 - 700 gram
Power supply	2,2 kW
Weight, net	approx 1100 kg
Weight, gross (carton+pallet)	approx 1175 kg

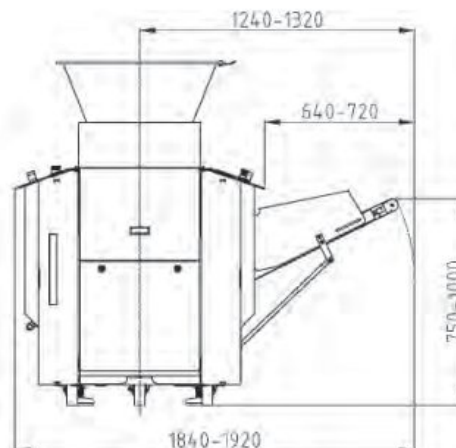

8/31/2021



P.O. Box 124 • S-280 64 GLIMAKRA • Sweden
Phone +46 44 449 00 • Fax +46 44 449 10
e-mail: office@glimek.se • www.glimek.se