

# BE-CONR-IND



## INDUSTRIAL CONICAL ROUNDER





## INDUSTRIAL CONICAL ROUNDER

This machine is designed with a rotating cone and adjustable spiral shaped tracks. The dough forms into a ball while moving from bottom to top along the track. The rounder is also equipped with a newly designed mechanical flour duster which produces minimal noise. The standard rounding track is 11.5 feet with a weight range from 3.5 - 85 ounces. An optional track makes it possible to produce between 2 - 7 ounces working weight range.

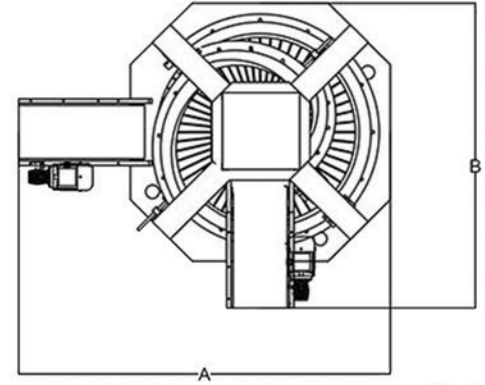
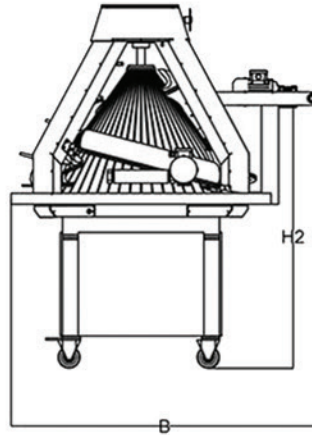
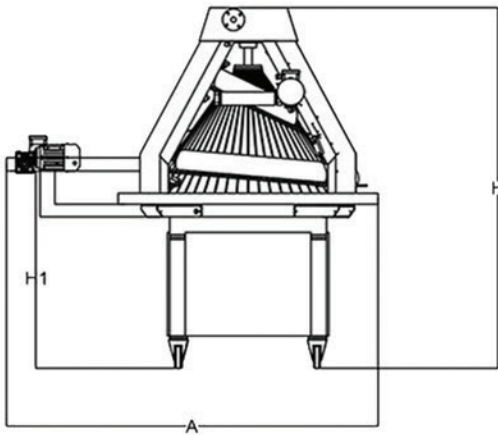
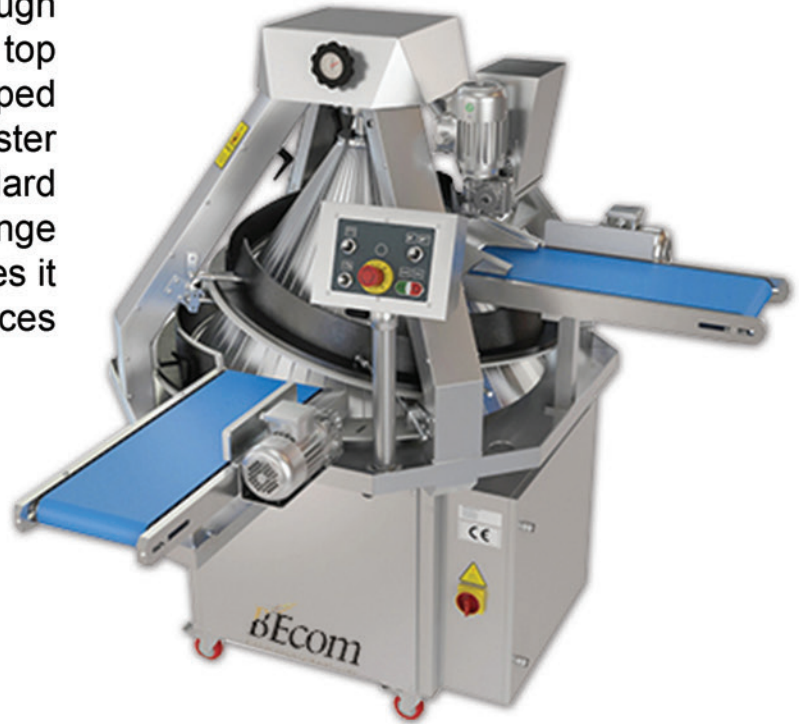

MODEL	CAPACITY (QTY/HR)	PROCESSING RANGE	ENTER/EXIT DIMENSIONS (H1 x H2)	MACHINE DIMENSIONS (A x B x H)	WEIGHT	POWER
BE-CONR-IND	1800 - 2400	3.5 - 85 oz	33" x 46"	52" x 65" x 64"	1411 lbs	208V - 3Ph - 60Hz - 15 AMPS