

BE-CD-1P



CHAMBER DIVIDER - 1 PISTON





CHAMBER DIVIDER - 1 PISTON

The BEcom Chamber Divider accurately and gently divides a wide range of doughs using a single piston to meet your production needs up to 1,200 pieces per hour. The components are made of Ni-Resistent materials to be wear-corrosion and oxidation resistant, and are designed for easy cleaning and maintenance.

FEATURES

- Dividing chamber, main piston, measuring piston, hopper base made of Ni-Resist material (wear-corrosion and oxidant resistant)
- Crankshaft made from cast iron
- BEKA brand oiling pump with 6 fixed dosing valves
- Drop hopper has a volume of 55 gallons and made from stainless steel
- Outer covers made of stainless steel
- Analog weight adjustment with position indicator
- Analog pressure adjustment of spring with position indicator
- Variable speed inverter
- 1.8 gallon oil reservoir, stainless steel indicator of insufficient oil supply
- Cross discharge conveyor (left or right hand side must be specified when placing order)

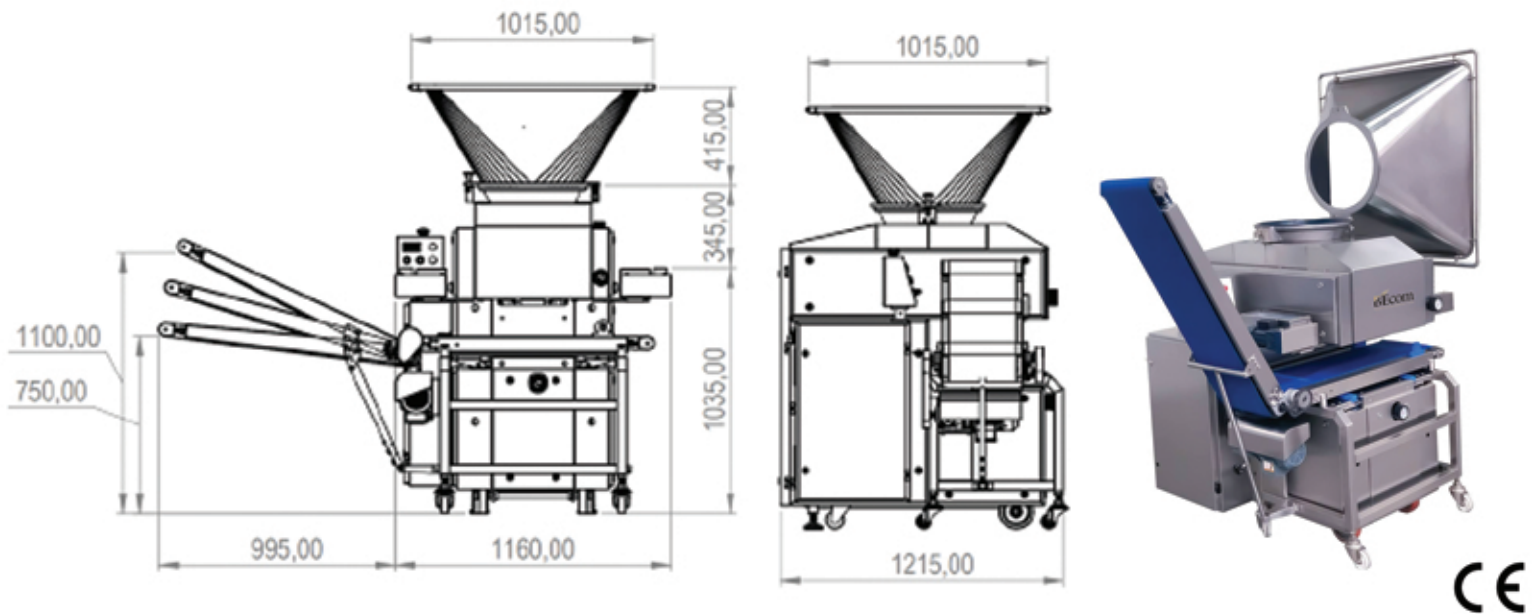

MODEL	CAPACITY (QTY/HR)	WEIGHT RANGE	# OF PISTONS	DIMENSIONS (D x W x H)	WEIGHT	POWER
BE-CD-1P	1200	14-84 oz	1	47.83" x 84.33" x 70.65"	1985 lbs	220V - 3Ph - 60Hz - 5 AMPs