

BE-CONR-IND



INDUSTRIAL CONICAL ROUNDER





INDUSTRIAL CONICAL ROUNDER

The industrial conical rounder machine responds to the need of small to large scale bakeries and is suitable for many common dough assortments, with perfect round moulding and minimal dough crumbs.

FEATURES

- Fully stainless-steel frame and surrounding panels
- Cast iron Teflon coated cone
- Aluminum tracks, in and outside Teflon coated
- Cast aluminum crumb collection tray, Teflon coated
- Cone speed controller by inverter
- Cone with top bearing
- Stainless steel round head cover
- Automatic flour duster
- Stainless steel swivel castors with mounting pins
- Easy in operation and cleaning
- Perfect separation between dough pieces coming from the divider
- Perfect transfer of dough pieces with outfeed chute

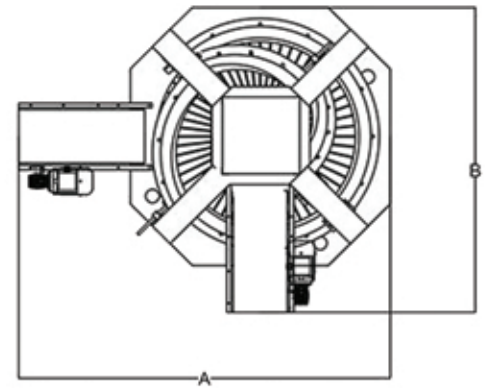
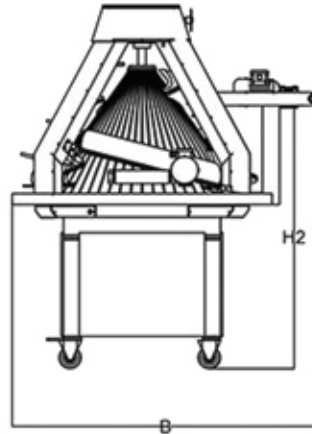
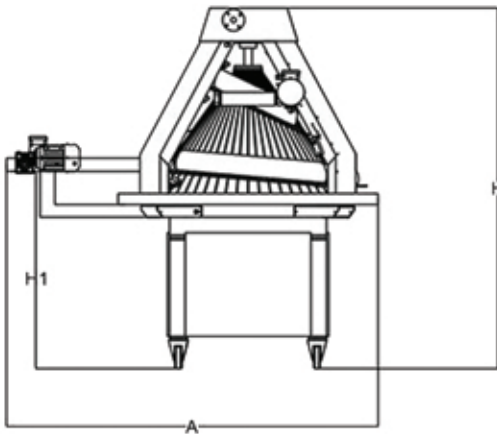

MODEL	CAPACITY (QTY/HR)	PROCESSING RANGE	MACHINE DIMENSIONS (L x W x H)	WEIGHT	POWER
BE-CONR-IND	Up to 3000	3 - 31 oz	46.65" x 46.65" x 57.28"	1322 lbs	208V - 3Ph - 60Hz - 4.55 AMPS