



FFBT EVO



Long loaf moulder for French “baguettes”

FFBT long loaf moulder is suitable for making French bread such as “baguettes”, “petit-pains”, “parisiennes” and – in wider terms – loaves and small loaves from high hydration dough requiring a very careful processing.

Standard features

- Aluminium alloy and steel structural frame painted with double anti-corrosion cycle and epoxy powder coating (suitable for food contact).
- Thermoformed ABS side outer paneling and control panel.
- Laminating of dough through two non-stick material-coated cylinders, rolling up through a mesh rolling up conveyor belt, extending of loaves through two wool-felt conveyor belts with opposite motion.
- Wool felt-coated chute for collection of loaves, foldable upwards.
- Laminating thickness and loaf length adjustment through micrometric steering.
- Very noiseless driving belts.
- Output performance: dough pieces ranging from a weight of min. 80 g up to max. 1000 g; approximate max. output: 1500 pieces/h (FFBT EVO)

Configurations

- FFBT EVO: Version for manual loading

Options

- Standard trolley: painted steel tubular support mounted on wheels

MODELS

FFBT EVO	Long loaf moulder for « baguette », manual loading
----------	--

Control panel

EDMD	Right-hand side (standard)
ESMS	Left-hand side

Accessories

Standard trolley	Tubular support with wheels
------------------	-----------------------------



FILONATRICE - FFBT EVO

Macchine NOR09R003/
Machines NOR09R003

FFBT EVO - LONG LOAF MOULDER

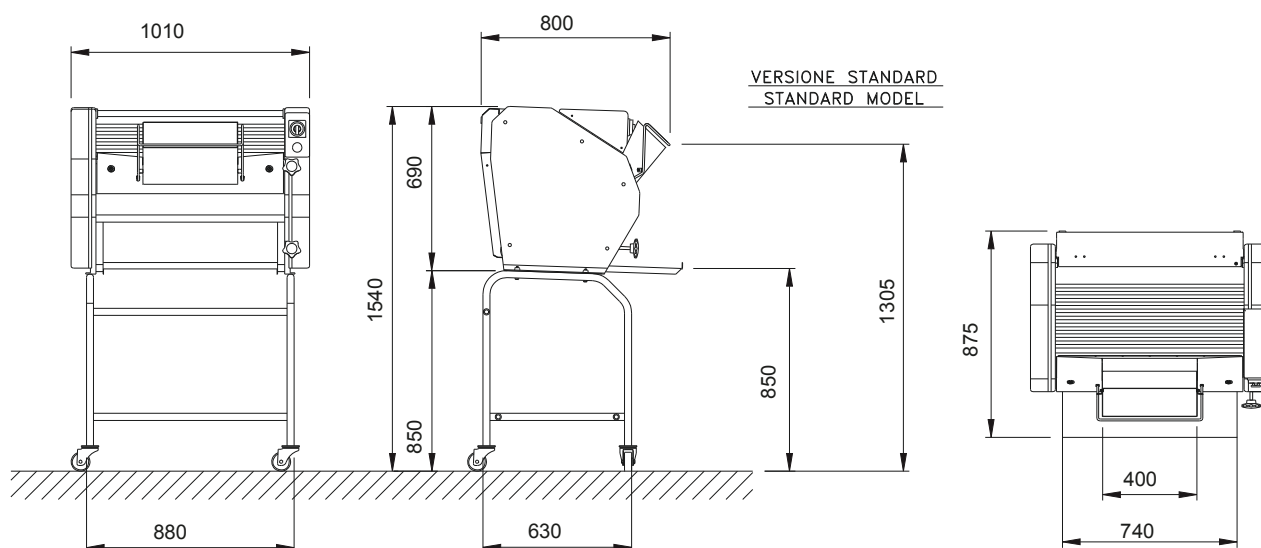
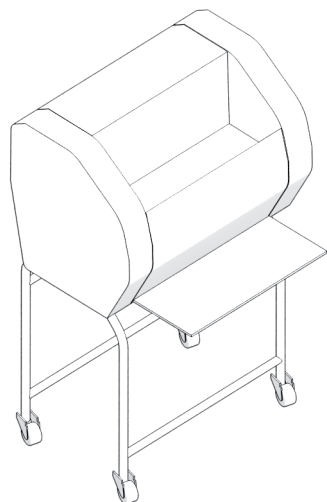

DATI TECNICI - TECHNICAL FEATURES

POTENZA INSTALLATA/INSTALLED POWER	kW	0,55
POTENZA MAX ASSORBITA/MAX. ABSORBED POWER	kW	0,55
INGOMBRO/OVERALL DIMENSIONS	mm	1010x800x690
INGOMBRO CON CARRELLO/OVERALL DIMENSIONS WITH RACK	mm	1010x800x1540
MASSA/MASS	kg	140
MASSA CON CARRELLO/MASS WITH RACK	kg	155
MASSA CON IMBALLO IN CARTONE/MASS WITH CARTON PACKING	kg	165
VOLUME IMBALLO IN CARTONE/CARTON VOLUME	m ³	0,75
CONNESSIONE ELETTRICA/PLUG COUPLING		3PH+Gr



FILONATRICE - FFBT EVO/A

Macchine 2002_024/
Machines 2002_024

FFBT EVO/A - LONG LOAF MOULDER

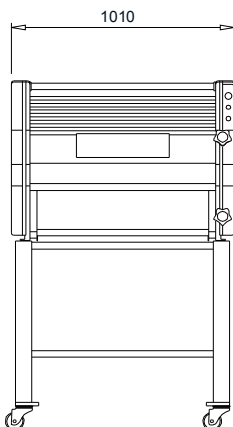
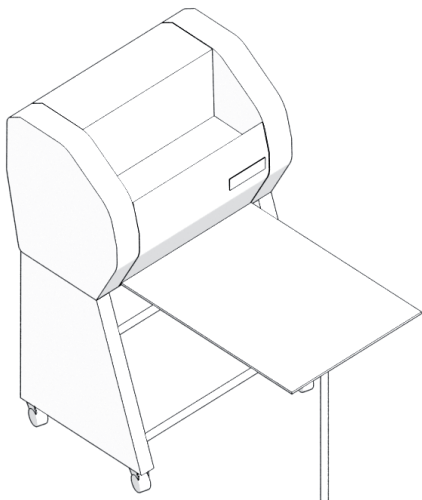
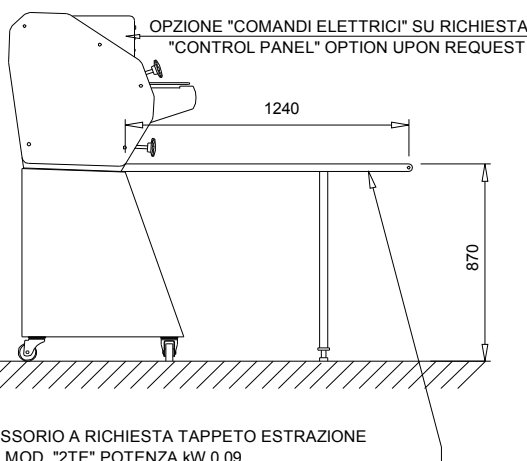
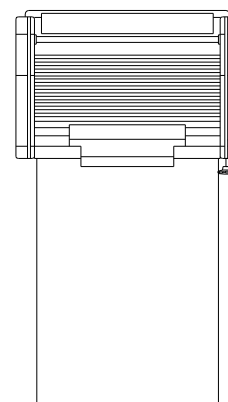
VERSIONE PER ABBINAMENTO ALLA CELLA DI PREFERMENTAZIONE "ECP"
MODEL FOR COMBINATION WITH INTERMEDIATE PROVER "ECP"OPZIONE "COMANDI ELETTRICI" SU RICHIESTA
"CONTROL PANEL" OPTION UPON REQUESTACCESSORIO A RICHIESTA TAPPETO ESTRAZIONE
PEZZI MOD. "2TE" POTENZA kW 0.09
ACCESSORY UPON REQUEST
EXTRACTION BELT TYPE "2TE" POWER kW 0.09

DATI TECNICI - TECHNICAL FEATURES

POTENZA INSTALLATA/INSTALLED POWER	kW	0,55
POTENZA MAX ASSORBITA/MAX. ABSORBED POWER	kW	0,55
INGOMBRO/OVERALL DIMENSIONS	mm	1010x800x690
INGOMBRO CON CARRELLO/OVERALL DIMENSIONS WITH RACK	mm	1010x800x1540
MASSA/MASS	kg	140
MASSA CON CARRELLO/MASS WITH RACK	kg	155
MASSA CON IMBALLO IN CARTONE/MASS WITH CARTON PACKING	kg	165
VOLUME IMBALLO IN CARTONE/CARTON VOLUME	m ³	0,75
CONNESSIONE ELETTRICA/PLUG COUPLING		3PH+Gr+N