

ASM EVO

SPIRAL MIXER WITH FIXED BOWL

MIXER
ART OF MIXING

PROFESSIONAL

CAPACITY (kg)

- 60 ▪100 ▪160 ▪250
- 80 ▪130 ▪200



TECHNICAL FEATURES

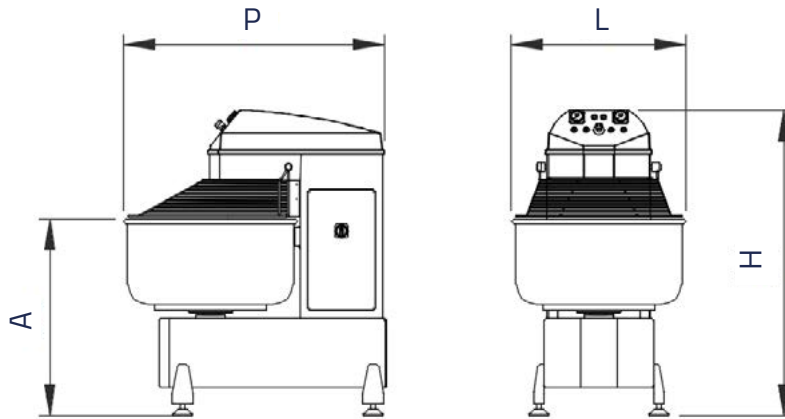

TECHNICAL DATA

MODEL		ASM EVO 60	ASM EVO 80	ASM EVO 100	ASM EVO 130	ASM EVO 160	ASM EVO 200	ASM EVO 250
Dough capacity (min./max) *	kg	5/60	8/80	8/100	10/130	10/160	10/200	15/250
Flour capacity (min./max) *	kg	3/38	5/50	5/62	6/80	6/100	6/125	9/150
Water capacity (min./max) *	lt	2/22	3/30	3/38	4/50	4/60	4/75	6/100
Bowl volume	lt	100	135	155	205	260	285	380
% water/flour minimum	%	50	50	50	50	50	50	50
Spiral turns 1st / 2nd speed (50/60Hz)	rpm	93/184	98/194	98/194	98/194	92/182	92/182	92/183
Bowl turns 1st / 2nd speed (50/60Hz)	rpm	10.5/21	10/20	10/20	9.5/19	9/18	9/18	9/18
Motor power 1st / 2nd speed	kw	2.35/3.25	2.9/5.3	2.9/5.3	3.6/6.3	4.6/7.4	4.6/7.4	5.4/8.6
Current drawn V 230 / V 400	A	12/7.8	20.5/12	20.5/12	23.5/15	34/17.2	34/17.2	34/20.5
Spiral bar diameter	mm	30	35	35	40	48	48	48
Height from bowl edge	A mm	890	900	955	950	927	957	990
Total depth	P mm	1040	1190	1190	1275	1460	1460	1565
Total width	L mm	635	745	745	845	945	945	1045
Total height	H mm	1360	1415	1415	1470	1500	1500	1500
Net weight	kg	300	390	395	460	650	650	680

*: capacity based on the percentage of liquid/flour = 60%

All data are to be considered as nominal, MIXER srl reserves the right to make any changes to the product and/or technical specifications without notice.

STANDARD FEATURES

- Painted steel structure raised from the ground on 4 adjustable feet.
- Bowl, spiral, contrast column and guard made in stainless steel.
- Two independent 2-speed motors for spiral and bowl.
- Movement is transmitted by pulleys and V-belts.
- Bowl thrust roller.
- Frontal control with two timers.
- Setting of work time with automatic shift from 1st to 2nd speed.
- Selector to reverse bowl.
- Impulse button to rotate bowl for product removal.
- Selector to activate second bowl speed.

ON REQUEST

- Stainless steel structure with micro shot-peening treatment.
- Computer with 7" monitor (able to program 100 recipes and to work in manual or automatic mode).
- Water dosing system.
- Spiral tool with oversized bar (not available on ASM 60 EVO).
- Spiral uprated motor (not available on ASM 60 EVO).
- Dough temperature probe.
- Bowl lid made of stainless steel with airtight polyethylene rim.
- Uprated tool speed for hydrated doughs.
- Bowl scraping device.
- Machine mounted on wheels (2 fixed rear wheels and 1 front pirouetting wheel).