

# 92500 Donut/Pastry Merchandiser



## Features & Finishes:

- Anodized Aluminum Frame
- Glass Front, Ends & Tops
- Aluminum Framed Tempered Glass Hinged Door(s)  
(29" L-2 Doors) (15" L-1 Door)
- White HPL Deck and Bag Bin
- White Wire Shelves (3)
- Top Acrylic Signage Panel (Sign not included)

**Spartan Showcase, Inc.**

A division of RHC/Spacemaster Corporation

e-mail: [sales@spartanshowcase.com](mailto:sales@spartanshowcase.com)

[www.spartanshowcase.com](http://www.spartanshowcase.com)

P.O. BOX 470  
Union, MO 63084

1.800.325.0775  
Fax 636.583.4067

# 92500 Series Donut/Pastry Merchandiser

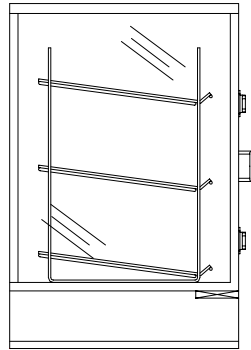

24" or 30"

End View

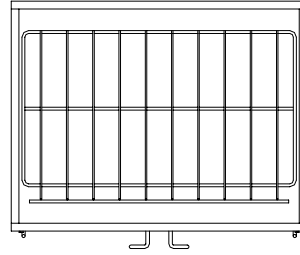

Top View

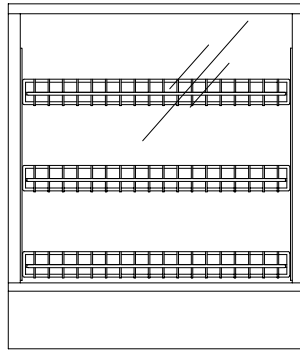

Front View

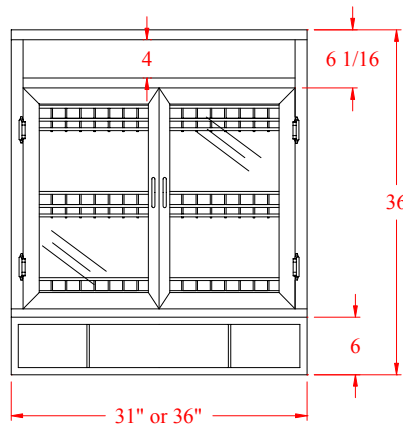

Rear View

Model No.	Dimensions: L x D x W	Rows of Shelves:	Est. Crated Weight
92531	31" x 24" x 36"	3	190 lbs.
92536	36" x 30" x 36"	3	210 lbs.

Case Options:
<ol style="list-style-type: none"> <li>1. Mirror Back</li> <li>2. Mirror Ends</li> <li>3. Top Light with Lamp, Shield, Cord, Plug and Switch</li> <li>4. Sign</li> <li>5. Pass-Through Doors Front &amp; Rear (Manual-Closing)</li> <li>6. "ETL" Sanitation Listed (Conforms to NSF STD-2)</li> <li>7. Self - Closing Doors</li> <li>8. Solid Pedestal Base 36"H</li> </ol>

Specifications Subject to change without notice

**Spartan Showcase, Inc.**

A division of RHC/Spacemaster Corporation

e-mail: [sales@spartanshowcase.com](mailto:sales@spartanshowcase.com)

[www.spartanshowcase.com](http://www.spartanshowcase.com)

P.O. BOX 470  
Union, MO 63084

1.800.325.0775  
Fax 636.583.4067

# 92500 Series Donut/Pastry Merchandiser

Model No.	Dimensions:	Rows of Shelves:	Est. Crated Weight
92531	31" x 24" x 36"	3	190 lbs.
92536	36" x 30" x 36"	3	210 lbs.

Code No.	CASE OPTIONS/ASSESSORIES
8940	1. Mirror Back
8920	2. Mirror Ends
9500	3. Top Light with Lamp, Shield Cord, Plug and Switch
	4. Sign
8570	5. Pass-Through Doors Front & Rear (Manual - Closing)
7030	6. "ETL" Sanitation Listed (Dry Case) (Conforms to NSF STD-2)
	7. Self-Closing Doors
	8. Solid Pedestal Base 36"H

## Spartan Showcase, Inc.

A division of RHC/Spacemaster Corporation

e-mail: [sales@spartanshowcase.com](mailto:sales@spartanshowcase.com)

[www.spartanshowcase.com](http://www.spartanshowcase.com)

P.O. BOX 470  
Union, MO 63084

1.800.325.0775  
Fax 636.583.4067