

MODEL K DIVIDER HEAD



- **Gentle Volumetric Bun, Roll, and Muffin Dividing**
- **Improved Design for Extended Machine Life and More Precise Scaling**

FEATURES & BENEFITS

New Design Improvements

- **Solid stainless steel cylinder (no welded wrap).** This design eliminates the potential for vacuum leaks due to weld failures.
- **Quick change cut-off wire assembly** significantly reduces downtime due to cut-off wire breakage.
- **Pneumatic gauges on both vacuum shoes** for easy operator monitoring of vacuum performance.

Maximum Scaling Performance

- **Obround piston shafts** eliminate shaft flexing to improve scaling performance.
- **New precision-machined segment gear assembly** provides exact operating performance.

MODEL K DIVIDER HEAD

MECHANICAL FEATURES

- New precision-machined UHMW hopper with maximum low-friction design
- Solid stainless steel drum (no wrap)
- Brass vacuum and pressure shoes
- Slotted hopper knife to accept optional hopper block-off assemblies
- Static body one-piece pistons with removable brass caps
- Obround piston shaft
- Precision segment gear assembly
- Bronze bearings
- Front drip and rear spray oilers
- Heavy duty, shock absorbing manual clutch or extended shaft for existing direct drive
- Stainless steel rear cover with Schmersal key safety interlock
- Pneumatic gauges on vacuum shoes

OPTIONS

- Dual oil pumping system
- Hopper block-off assemblies
- 2" (51 mm) diameter pistons in place of standard 2 1/2" (64 mm) diameter pistons (scaling range of .75 oz./21 g to 3 oz./85 g)
- Round operating shaft in lieu of obround for increased scaling range
- 250 lb. (113 kg) stainless steel extension hopper
- 500 lb. (227 kg) stainless steel extension hopper
- Air clutch option
- Right hand controls
- Oil mist collector system
- Quick change cut-off assembly
- Cast hopper in lieu of UHMW hopper

SPECIFICATIONS

	Scaling Range	Speed Range	Pneumatic Requirements ²	Approximate Shipping Weight
K-400	1 - 5 oz. (28 - 142 g) ¹	40 - 100 cpm	25 SCFM @ 87 PSIG	1,300 lb. (590 kg)
K-600	1 - 5 oz. (28 - 142 g) ¹	40 - 100 cpm	25 SCFM @ 87 PSIG	1,500 lb. (680 kg)

¹ Range may be increased with special pistons and/or shafts

² Pneumatic requirements using Piab Vacuum System

DIMENSIONAL DRAWING

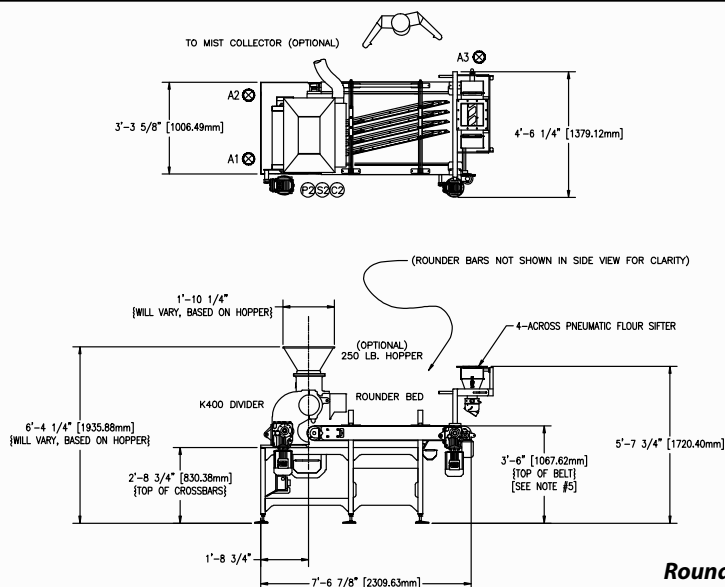

Headquarters:
 2115 W. Laburnum Ave.
 Richmond, Virginia 23227
 Tel: 1-800-225-3771
 or 1-804-355-7961
 Fax: 1-804-342-9724
sales@amfbakery.com

Europe Office:
 6 The Sidings
 Station Road, Guiseley
 Leeds LS20 8BX, England
 Tel: 44-1943-875703
 Fax: 44-1943-871806
sales-europe@amfbakery.com

Asia Office:
 Room 15-2, A-Building
 Thunis Dev. Building
 No.11 Hui Xin East St.
 Chaoyang District
 Beijing, China 100029
 Tel: 86-10-64823613
 Fax: 86-10-64934259
sales-asia@amfbakery.com

FOR MORE INFORMATION PLEASE CALL YOUR ACCOUNT MANAGER OR

1-800-BAKERS-1
www.amfbakery.com

AMF's focus on continuous improvement may result in changes to machinery specifications without notice.



K-Head 2.5" (64 mm) Diameter Piston Production Chart

Obround Shaft (Standard)

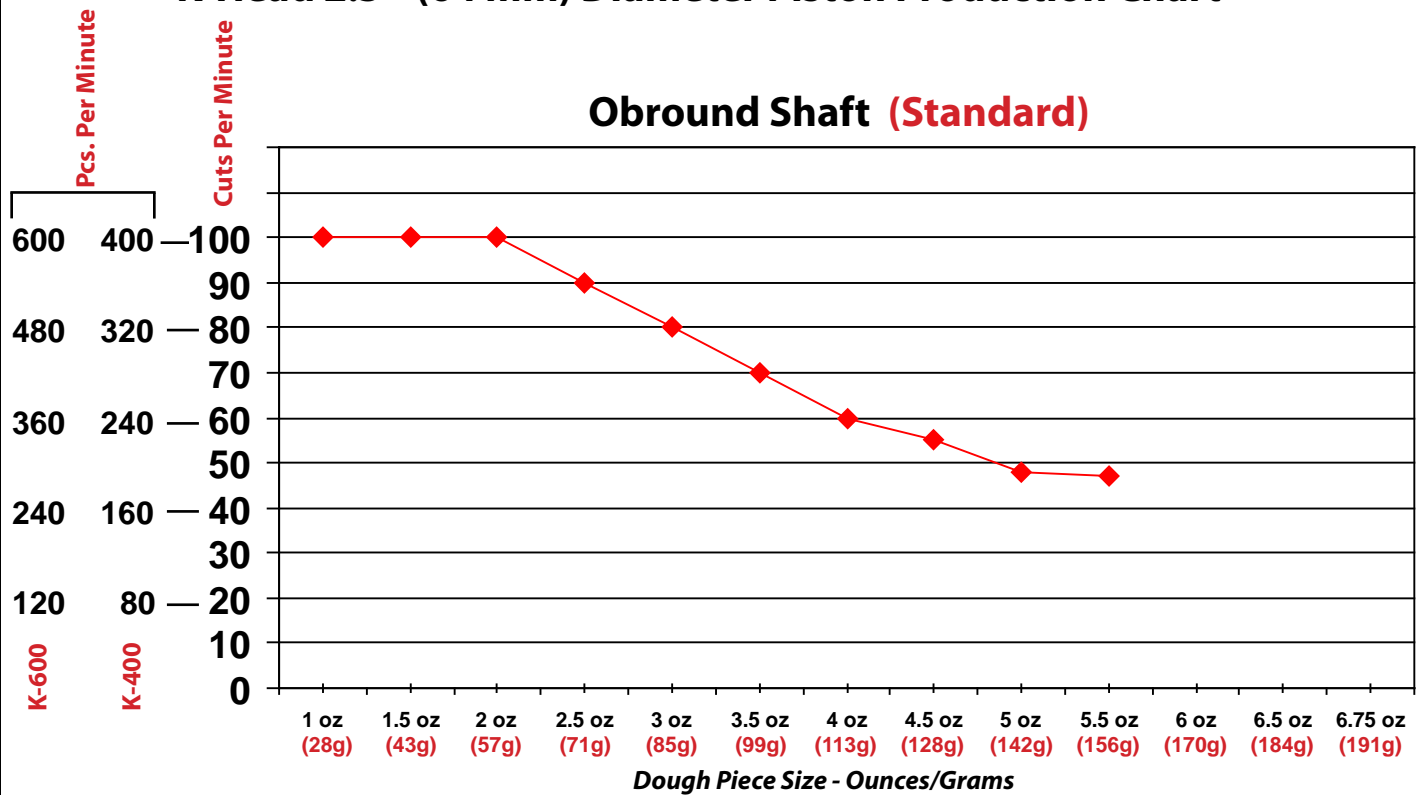

Round Shaft

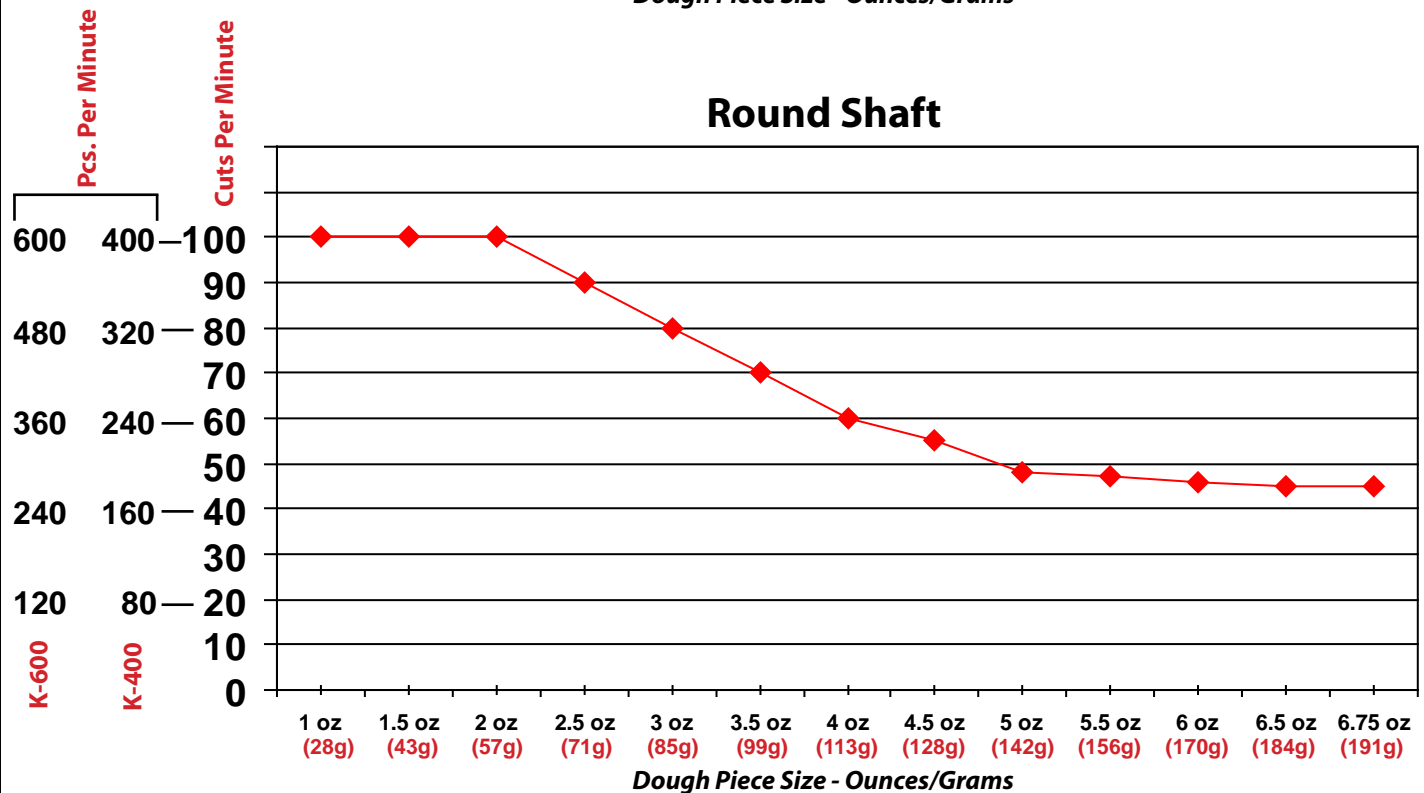

Notes:

1. Speed/weight chart is based for running standard soft roll dough, compatible with Model "K" Roll machines.
2. To maintain production as desired, the Model "K" Roll machine should be maintained clean and in good working order as per instructions in the operation, maintenance and lubrication sections of the Model "K" manuals.
3. Rates shown are maximum rates.



K-Head 2" (51 mm) Diameter Piston Production Chart

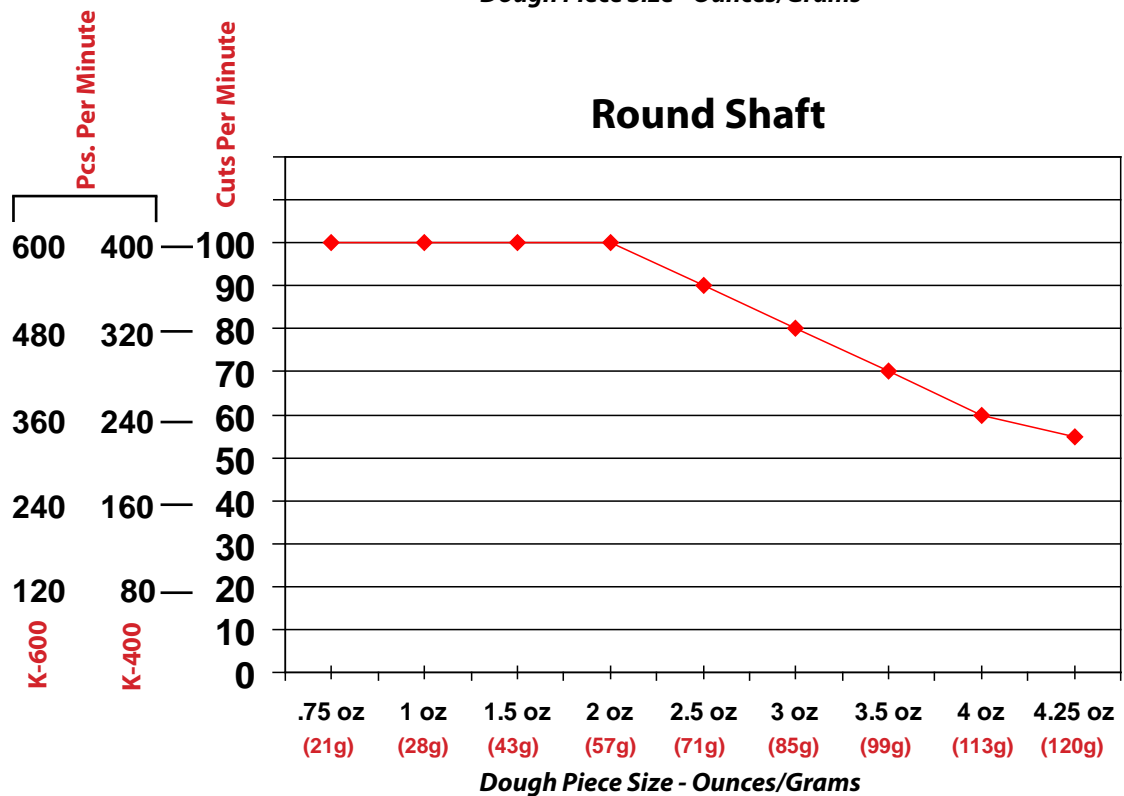
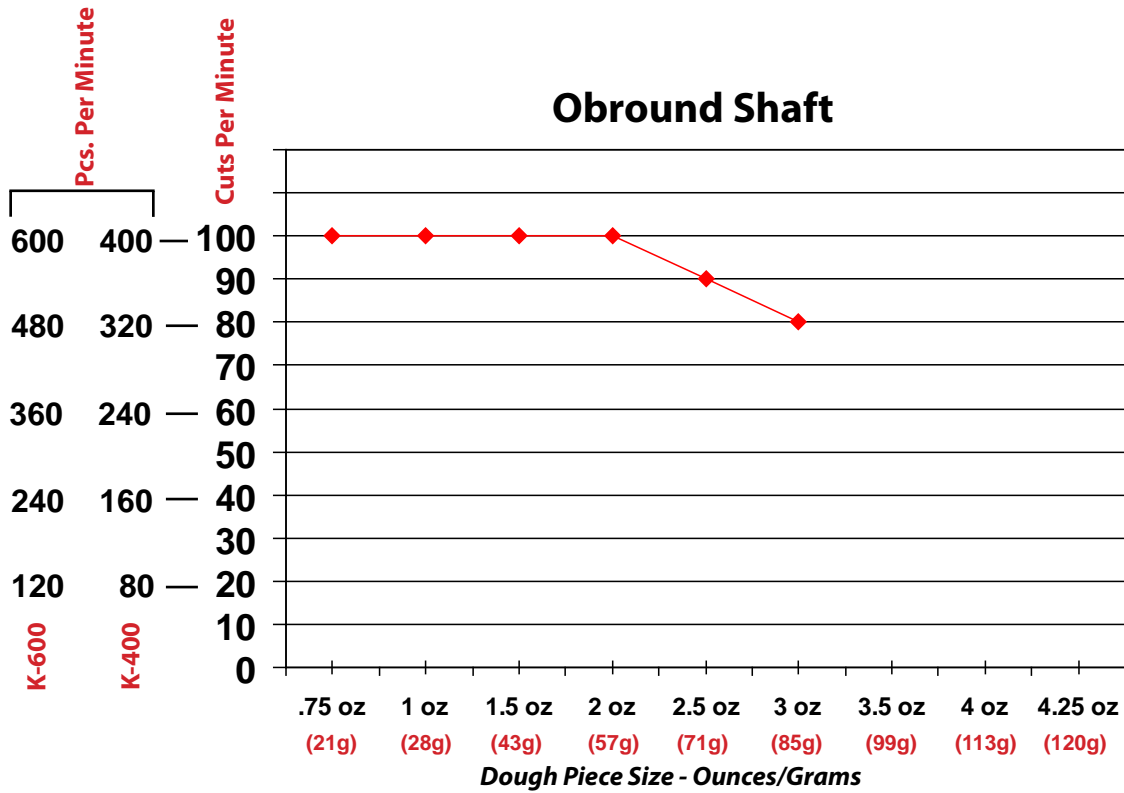

Notes:

1. Speed/weight chart is based for running standard soft roll dough, compatible with Model "K" Roll machines.
2. To maintain production as desired, the Model "K" Roll machine should be maintained clean and in good working order as per instructions in the operation, maintenance and lubrication sections of the Model "K" manuals.
3. Rates shown are maximum rates.

AMF

MODEL K DIVIDER HEAD REMANUFACTURED

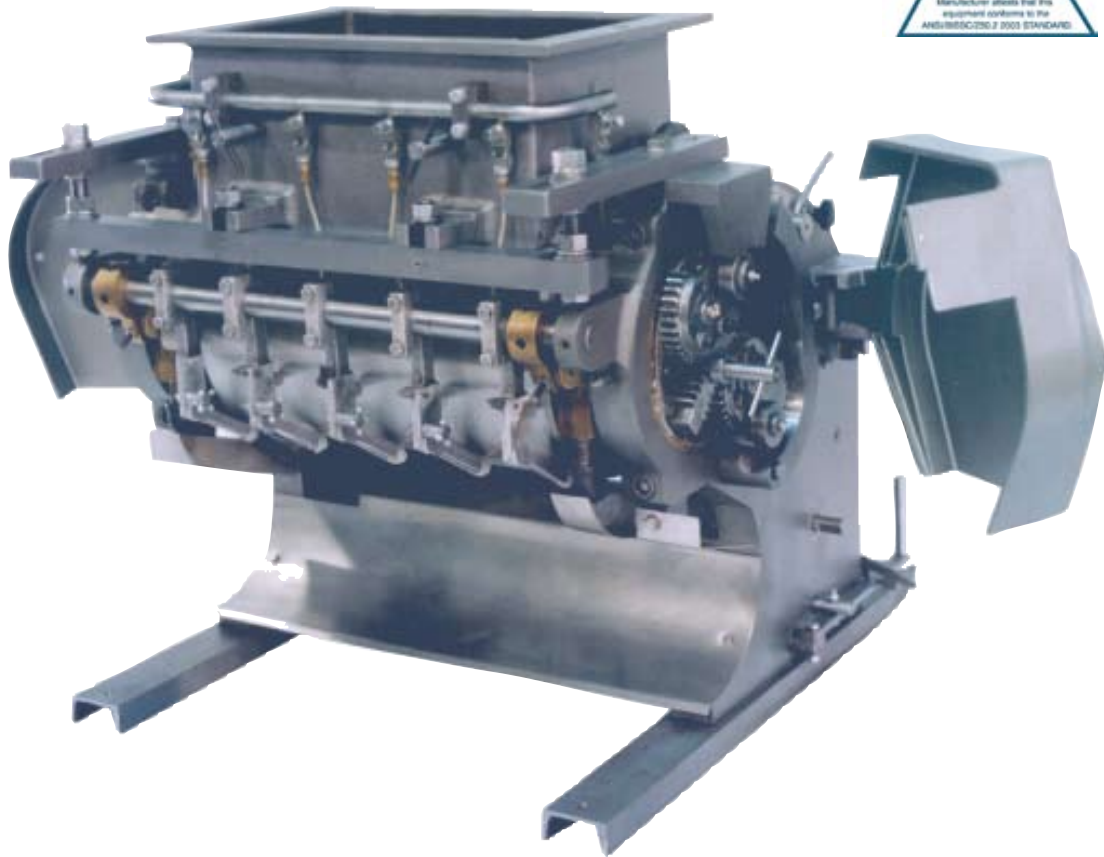

- Remanufactured Stainless Steel Replacement Head Assembly for Installation on Existing K-Roll Machine
- Completely Remanufactured
- 90% New Components
- Reliable Performance

REMANUFACTURED

AMF

MODEL K DIVIDER HEAD REMANUFACTURED

The machine and all its components are disassembled, dipped into an acid bath and cleaned to bare metal. A thorough inspection is then conducted in order to replace all worn parts. The frame is repaired as needed and coated with "Steel-it" (stainless steel epoxy paint) in preparation for assembly.

MECHANICAL FEATURES

- NEW or fully remachined hopper with maximum low friction design
- NEW stainless steel drum lining 12" (30 cm) O.D. and piston sleeve machined to original specifications
- NEW vacuum shoes
- NEW static body pistons
- NEW oblong shaft
- NEW rack gear
- NEW chains and sprockets
- NEW bronze bearings
- NEW oiling system with rear oiler
- NEW shock absorbing clutch
- NEW stainless steel rear cover with safety keyed switches required to meet OSHA

OPTIONS

- Dual oil pumping system
- Hopper block-off assemblies
- Piston block-off assemblies
- 2" (5 cm) diameter pistons in place of standard 2 1/2" (6 cm) diameter pistons (scaling range of 7/8 oz. to 3 oz.)
- Round operating shaft in lieu of obround for increased scaling range
- 250 lb. (113 kg) stainless steel extension hopper
- 500 lb. (226 kg) stainless steel extension hopper
- Air clutch in lieu of manual clutch
- Right hand controls
- Oil mist collector systems
- Quick change wire assembly
- Tool kit
- Spare parts kit

SPECIFICATIONS

	Scaling Range	Speed Range	Pneumatic Requirements ²	Approx. Shipping Weight
K-400	1 - 5 oz.¹	160 - 400 ppm	25 SCFM to 87 PSIG	1300 lb. (589 kg)

¹ Range may be increased with special pistons and/or shafts

² Pneumatic requirements using Piab MLL 200

DIMENSIONAL DRAWING

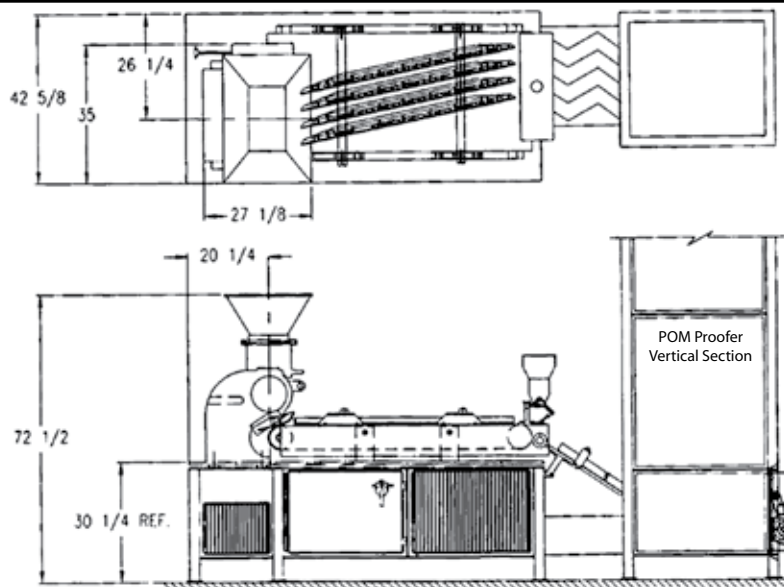

Left Hand Shown with
 250 lb. (113 kg.) Hopper

Headquarters:
 2115 W. Laburnum Ave.
 Richmond, Virginia 23227
Tel: 1-800-225-3771
 or 1-804-355-7961
Fax: 1-804-342-9724
sales@amfbakery.com

Europe Office:
 6 The Sidings
 Station Road, Guiseley
 Leeds LS20 8BX, England
Tel: 44-1943-875703
Fax: 44-1943-871806
sales-europe@amfbakery.com

Asia Office:
 Room 15-2, A-Building
 Thunis Dev. Building
 No.11 Hui Xin East St.
 Chaoyang District
 Beijing, China 100029
Tel: 86-10-64823613
Fax: 86-10-64934259
sales-asia@amfbakery.com

FOR MORE INFORMATION PLEASE CALL YOUR ACCOUNT MANAGER OR

1-800-BAKERS-1
www.amfbakery.com

AMF's focus on continuous improvement may result in changes to machinery specifications without notice.