

NON-INSULATED UNIVERSAL ANGLE CABINETS 103-UA SERIES

FEATURES AND BENEFITS:

- Non-insulated versatile cabinet for transport and storage.
- Same size top and base extend past sidewalls to act as natural bumpers for protection. Extruded frame fully welded.
- Body constructed of non-corrosive, Hi-Tensile aluminum for strength and ease of mobility.
- Reinforced, full length door swings 270° and can be latched to the cabinet side for convenience. Card clip included.
- Gravity type latch secures door during transport.
- Chrome plated wire universal angles accommodate a large variety of pan sizes on adjustable 1-1/2" centers.
- Interior pan stops on door and back allow proper air flow.
- Heavy duty 5" swivel casters, two with brakes. Provides mobility when fully loaded.



103-UA-13D



ACCESSORIES and OPTIONS (Available at extra cost):

- Lock Hasp
- Various Caster Options
- Corner Bumpers
- Perimeter Bumper
- Floor Lock (for use with 5" casters)
- Push Handle
- Bail Handle Kit
- Left-Hand Hinged Door
- Extra Universal Angles
- Transport Angles
- Kold Keepers

See page A-20 for accessory details.

103-UA Series

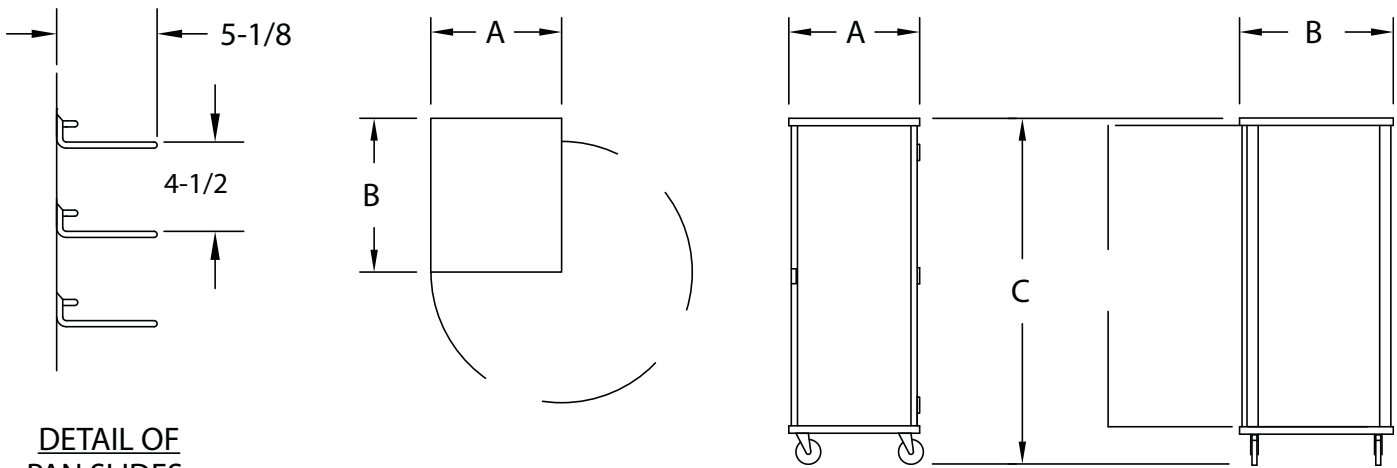

**DETAIL OF
PAN SLIDES**

CRES COR MODEL NO.	PAN			DIM "A"	DIM "B"	DIM "C"	INSIDE DIMENSIONS				WEIGHT ACT.
	CAP	SIZE		WIDTH	DEPTH	HEIGHT	WIDTH	DEPTH	HEIGHT		
103-UA-13D	13 SETS	SEE NOTE BELOW	IN	25-13/16	31	69-3/4	21-3/4	28-1/2	61-1/2	LBS	157
			MM	660	790	1775	555	725	1565	KG	71
103-UA-11D	11 SETS	SEE NOTE BELOW	IN	25-13/16	31	57-3/4	21-3/4	28-1/2	49-1/2	LBS	150
			MM	660	790	1470	555	725	1260	KG	68

NOTES: 1. Pan sizes 22" x 20" (560 x 510) Roast & Bake Pans, 10" x 20" (255 x 510) Roast & Bake Pans, 18" x 26" (460 x 660) Bun Pans, 14" x 18" (355 x 460) Service Trays, 12" x 20" (305 x 510) Steam Table Pans.
Refer to Pan Size Chart at end of section.
2. When ordering bumpers, add 2" to overall dimensions.

ALL ALUMINUM CONSTRUCTION IS RIVETED, WELDED AND FINISHED.

CABINET:

- Posts: Extruded channels, 7/8 x 2-1/4 x .102, welded to top and base, form a solid frame.
- Sides and back: .063 panels riveted to posts.
- Back panel: Fitted into posts, riveted to top and reinforced.
- Top: One piece .100 aluminum.
- Pan stop channels: Mounted to inside rear of cabinet and door.

BASE:

- One piece construction, .190 aluminum.
- Casters: 5" dia., swivel, modulus tires, 1-1/4 wide, load cap. 250 lbs. each, temp. range -45°/+180°F. Delrin bearings. Front casters equipped with brakes.

DOOR:

- Panel: Formed .100 aluminum.
- Reinforcement: 1/4 x 1-1/2 extruded bars riveted horizontally to top, center and bottom.
- Latch: Gravity type, nickel plated steel.
- Swings 270° on 3 butt hinges, riveted to posts and door.

PAN SLIDES:

- Wire angles (.306 dia.), nickel chrome plated steel, mounted on lift-out posts.
- Spaced on 4-1/2" centers; adjustable on 1-1/2" centers.

SHORT FORM SPECIFICATIONS

Cres Cor Utility Cabinet Model 103-UA-_____ D.
Formed and welded .100 aluminum top, .190 aluminum base. (____) sets wire universal angles for multiple pan sizes, adjustable spacing every 1-1/2".
Formed .100 aluminum reinforced door. 5" swivel modulus casters, Delrin bearings. Load capacity 250 lbs. each. Provide the following accessories: _____
_____. NSF listed. 2 year parts warranty.



5925 Heisley Road • Mentor, OH 44060-1833
Phone: 877/CRESCOR • Fax: 440/350-7267
www.crescor.com

© Crescent Metal Products, Inc. 2008 All rights reserved.

In line with its policy to continually improve its products, CRES COR reserves the right to change materials and specifications without notice.

Litho in U.S.A.