

# DOUGHPRO

## Consistent Crust Every Time

### DP1100 High Production Manual Dough Press

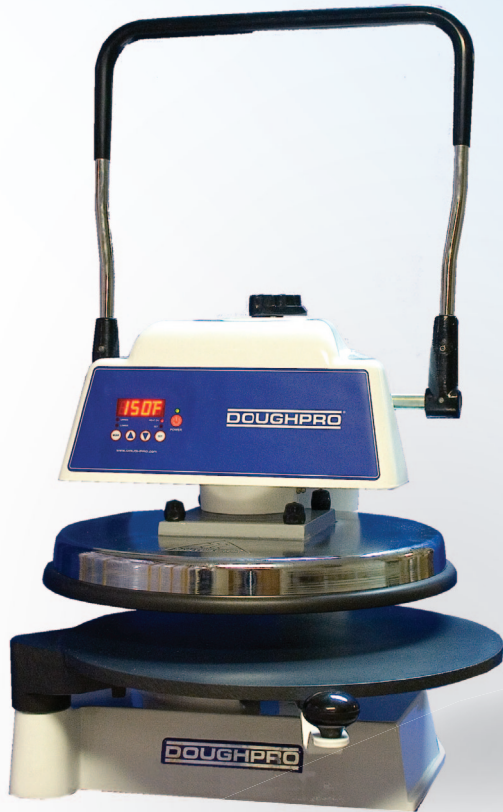

Press consistent crusts every time...without the need for skilled labor! This heavy-duty manual press revolutionized the pizza industry. Based on our exclusive patented technology, the ProLuxe DP1100 offers a top heated platen that will form pizza dough in just a few seconds. The manually operated, easy-to-maneuver action creates consistent product every time, and is backed by our exclusive ProLuxe limited lifetime warranty. The thickness control allows you to press dough from paper thin to 1/4" thick. Press up to an 18" product in just seconds!

#### Features

- Manually operated, no motor or compressors required.
- Produces crusts equal to hand tossed product.
- Safe to operate and clean.
- Compact size fits just about anywhere.
- Heated upper platen enhances the baking qualities.
- Backed by our exclusive ProLuxe limited lifetime warranty.

In addition to the quality execution and unique customization capabilities, our expert technical support team supports the ProLuxe DP1100. We are available 24 hours a day/7 days a week to answer any questions and provide you with great, no-debate service support.

**PROLUXE** 

formerly DoughPro. New Name. Same Quality. Superior Service.

[proluxe.com](http://proluxe.com)

# DOUGHPRO

## Consistent Crust Every Time

### DP1100 High Production Manual Dough Press

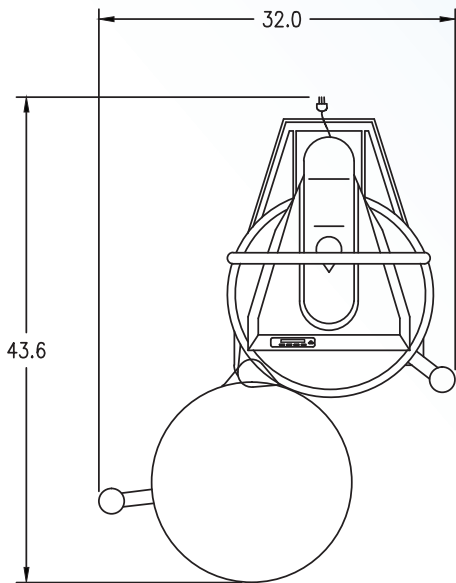

TOP VIEW

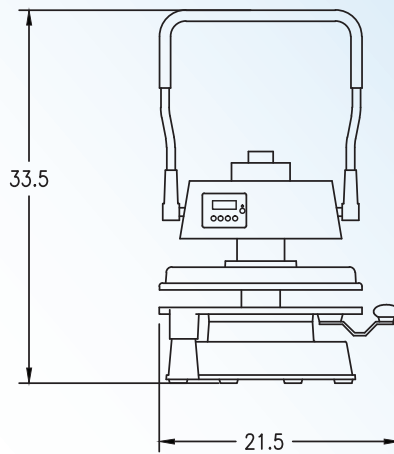

FRONT VIEW

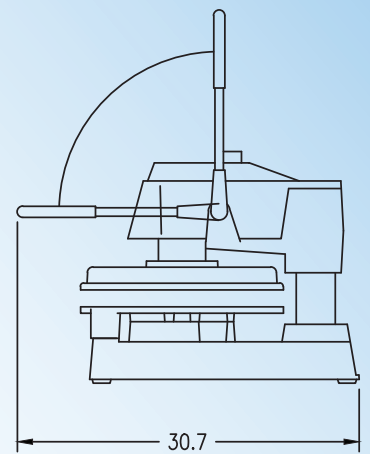

RIGHT SIDE VIEW

<b>ON/OFF Switch</b>	Yes	<b>Electrical Data</b> 120v/60hz 2200w/18.3 amps
<b>Programmable Timer</b>	Yes	
<b>Temperature Control</b>	Yes	220v/50/60hz 2200w/10.0 amps
<b>Thickness Adjustment</b>	Yes	<b>Shipping Weight</b> 175lbs/79kg
<b>Maximum Heat</b>	0-450 F	<b>Machine Weight</b> 140lbs/63kg

Includes 72" cord and NEMA 5-20/6-20 plug

Listed:



**PROLUXE** 

20281 Harvill Ave | Perris, CA 92570  
t: (951) 657-0379 | t: (800) 624-6717 | f: (951) 657-4594  
w: [www.proluxe.com](http://www.proluxe.com) | e: [info@prolux.com](mailto:info@prolux.com)