

Bagel Kettle and Hood

Features

- 45 Gallon Capacity
- Removable Tank and Backsplash
- Insulated Body with Mineral Wool
- Heavy Duty Two-Ring Burner with Control Valve
- Perforated Tray (removable for easy cleaning)
- 2" Drain Line
- 8" Flue Outlet
- 100% Shutdown Safety Gas Valve Pilot
- 6" Legs (1" adjustable)



Heavy Duty for Better Bagels

Our stainless-steel, trouble-free bagel kettle consistently produces 4,000 bagels hour after hour. We use only the highest quality material and components. This ensures you quick recovery, the highest quality and years of reliable service. ETL gas approved assures code compliance.

EMP-BK and EMP-KH Technical Data

Kettle Specifications					
Capacity*	Tank Dimensions		Gas		Flue Outlet
	Inside Diameter	Inside Deep	Connection	BTU/hr.	
45 gal.	29"	16"	3/4"	200,000	8"

*Also available in 25-gallon capacity with 3 ft. square hood

10/13/04



#386-83-E

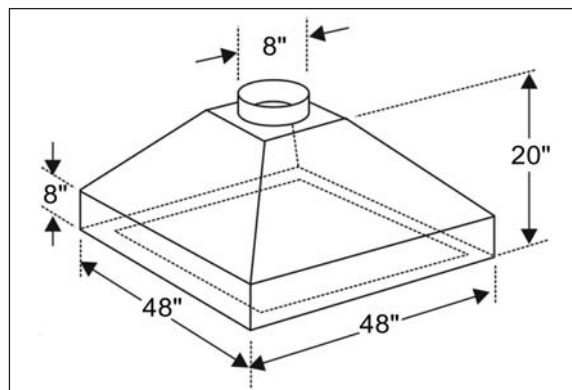
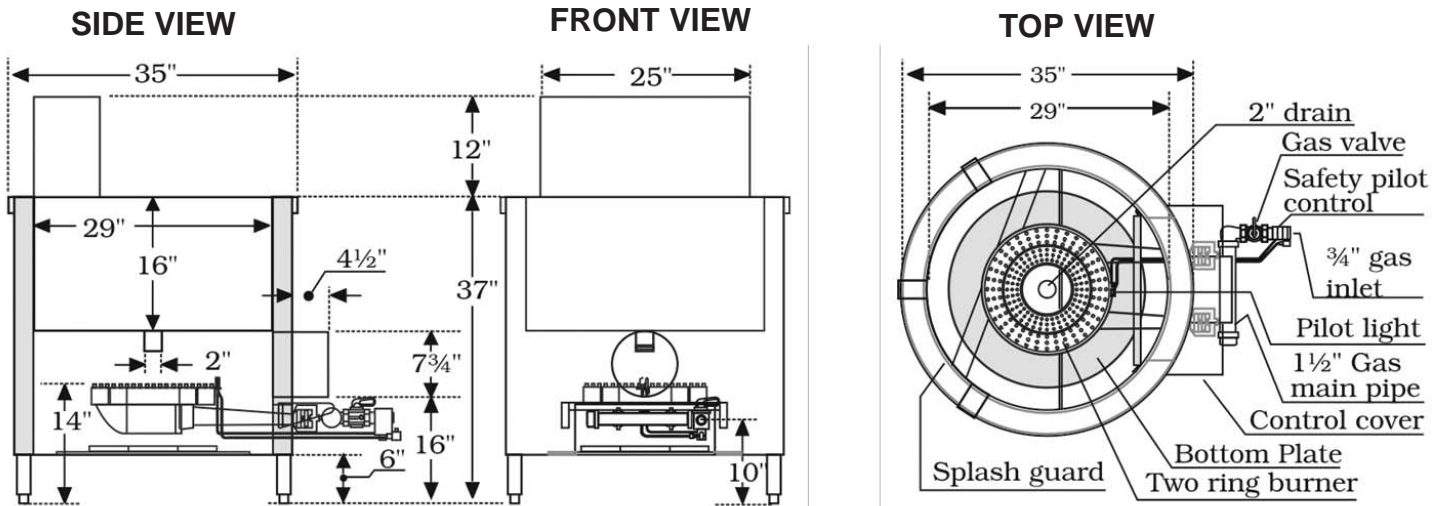

HOOD

NOTE: Specifications are subject to revision and confirmation.

BKBH.03



1 C Enterprise Place, Hicksville, NY 11801-5356 ■ ph: 516-681-1500 ■ fx: 516-681-1510
 1-800-878-4070 ■ www.empirebake.com ■ [email: info@empirebake.com](mailto:info@empirebake.com)