

## FIXED BOWL MIXERS / MIXER WITH HOIST OPTION

### MODEL: CG/450KG-ST

One of the many advantages of the spiral mixer is the superior oxygenation of dough. By ideally positioning the Separation Bar and Spiral Arm, our mixer achieves optimally oxygenated dough while processing gently enough to maintain the integrity of the yeast. The result is increased volume and minimal increase of dough temperature.

The CG/450KG-ST Spiral Mixer economically processes 993 pounds of finished dough — a quantity once limited to other types of mixers.

The CG/450KG-ST can be configured as a standard Two Speed model fitted upon a hoist, or with a Programmable Logic Control (PLC) drive system with variable speed capability. Set at a low height the Hoist deposits dough into a trough or onto a table. It can also be set higher to deposit dough directly into another machine for further processing.

The flexibility of the PLC Drive System makes it possible to program the unit for various mixing needs. With optional software and hardware, the unit can be programmed to stop the mixing process at a certain dough temperature. More detailed programming is also available, such as specific RPMs for different types of dough. The ability to program many different RPMs and mixing times for various dough recipe's makes this spiral mixer easy to use in the bakery. Simply call up the program and initiate the work cycle via the panel. Our automated system results in precise mixing and high productivity.

Short of a manual probe in the dough, the optional temperature sensor is the most accurate method of measuring dough temperature. The digital screen on the operator's panel is configured in Celsius or Fahrenheit.

The CG/450KG-ST Spiral Mixer was built to process high gluten content dough for prolonged periods. The mixer features a stainless steel bowl, separation bar, and spiral arm. All components are top quality and CSA approved and/or UL Listed. Larger models available upon request. Please inquire.



**CINELLI**  
**ESPERIA**  
CORPORATION

380 Chrislea Road,  
Woodbridge, Ontario  
L4L 8A8 CANADA

Tel: (905) 856-1820; 850-1800  
Fax: (905) 850-2989  
Web Site: [www.cinelli-esperia.com](http://www.cinelli-esperia.com)



Printed in Canada

© DESIGNATED TRADEMARK REGISTERED IN CANADA, USA, MEXICO & RUSSIA  
OWNED BY G. CINELLI - ESPERIA CORPORATION

## FIXED BOWL MIXERS / MIXER WITH HOIST OPTION

North America is renowned for producing the world's best flour due in part because our wheat yields one of the highest gluten contents available. Imported bakery equipment, specifically mixers, are generally not designed to cope with the extra stresses imposed by high-gluten flour, thus being prone to premature failure.

Being specifically designed for these stresses and being manufactured in North America, our Spiral Mixer line was an instant success, garnering a reputation as North America's most durable, superior mixing, and most complete line available.

From the CG/60kg. Model to the CG/300kg. Model; rest assured that all feature reinforced heavy duty construction that has made them a symbol of quality. All feature two speeds with two timers for separate speed programming, forward and reverse bowl rotation for better amalgamation of ingredients, as well as a high speed on/off selector switch.

The Bowl, Separation Bar, and Spiral Arm are made of high grade Stainless Steel. Due to the utilisation of our multiple V-belt transmission, the mixers provide superior torque, are low in maintenance, inexpensive to maintain, as well as very quiet during operation. All mixers are ETL Sanitation approved according to NSF Standard #8 regulations.

As far as power requirements are concerned, we are also able to offer different voltage configurations to accommodate any regional requirement.

Be sure to inquire about our unique proprietary Microprocessor controlled Operator Panel. With capabilities of storing up to 1,000 programs. Optional "Wash Down" versions for federally inspected plants available upon request.



**CINELLI**  
**ESPERIA**  
CORPORATION

Our Goal is Simple...  
To Help You Reach Yours

Manufacturers of  
Quality Bakery Machinery  
Since 1972.

CG/60  
CG/100  
CG/130  
CG/160  
CG/200  
CG/250  
CG/300  
CG/450



G. CINELLI-ESPERIA CORPORATION®, redefining standards of Quality and Service

# HOIST DEPOSIT SYSTEM

The Hoist Deposit System option is an indispensable tool for high output operations, or for baking operations that seek to improve efficiency.

The Hoist Deposit System is an option available for the CG/160KG models and larger. The system allows the operator to dump finished dough onto a worktable, into a Dough Trough, or directly into the hopper of a machine such as our CG/VBD Dough Divider for further processing. It eliminates the need for separate bowls and bowl elevator systems, thereby reducing expenditures on equipment, reducing time between mixing cycles, and reducing space requirements. The system also reduces injuries associated with manually cutting and removing the dough from the bowl by hand.

The Heavy Duty Hoist is designed to withstand countless operations without frame distortion. Specifically reinforced to cope with payloads much heavier than the hoist will ever lift, it was also designed to maintain stability and an appropriately distributed centre of gravity completely through the lifting cycle.

The Hoist option is available for Right or Left side deposit as well as Low or High deposit ranges as illustrated.

- STL-L = Hoist with Left Side Low Deposit
- STL-H = Hoist with Left Side High Deposit
- STR-L = Hoist with Right Side Low Deposit
- STR-H = Hoist with Right Side High Deposit

MIXER WITH HOIST OPTION	DIMENSIONS							
	A		B		C		D	E
	Hoist option		Hoist option		Hoist Option			
	High	Low	High	Low	High	Low		
CG/160 kg	121 inches 3073 mm	107 inches 2718 mm	96 inches 2438 mm	88 inches 2235 mm	66 inches 1676 mm	52 inches 1321 mm	56 inches 1422 mm	78 inches 1981 mm
CG/200 kg	121 inches 3073 mm	107 inches 2718 mm	96 inches 2438 mm	88 inches 2235 mm	66 inches 1676 mm	52 inches 1321 mm	56 inches 1422 mm	78 inches 1981 mm
CG/250 kg	121 inches 3073 mm	112 inches 2845 mm	97 inches 2464 mm	88 inches 2235 mm	66 inches 1676 mm	48 inches 1219 mm	67 inches 1702 mm	81 inches 2057 mm
CG/300 kg	121 inches 3073 mm	112 inches 2845 mm	97 inches 2464 mm	88 inches 2235 mm	66 inches 1676 mm	48 inches 1219 mm	67 inches 1702 mm	81 inches 2057 mm
CG/450 kg	130 inches 3302 mm		110 inches 2794 mm		58 inches 1473 mm		88 inches 2235 mm	104 inches 2642 mm

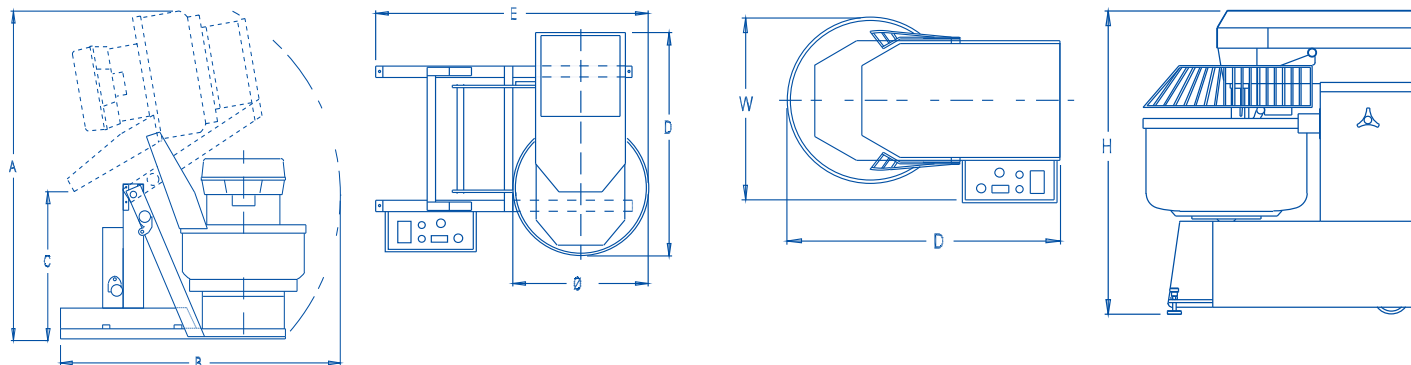

All Data Not Binding

G. CINELLI-ESPERIA CORPORATION®, redefining standards of Quality and Service

# FIXED BOWL MIXERS / MIXER WITH HOIST OPTION

Manufacturers of North America's Premier Spiral Mixing line, G. CINELLI - ESPERIA CORPORATION® maintains this fore running position by producing mixers that are exceptionally low in maintenance, extremely durable and machines that produce superior results where dough development is concerned.

The machine is a superior mixing unit designed to significantly reduce the operating time of the traditional mixers fitted with forks or dual arms.

One of the many advantages our spiral mixer offers is the superior oxygenation of dough. By ideally positioning the Separation Bar and Spiral Arm respective to the bowl, our mixer is able to achieve optimally oxygenated dough while processing the dough gently and thus maintaining the integrity of the yeast. The end result is increased volume, longer yeast viability, and remarkably minimal temperature increase of the dough. All of which are compromised in Planetary or Horizontal Mixers.

As with all of the machines built at G. CINELLI - ESPERIA CORPORATION®, our mixers are built to withstand the rigors of daily use in the harshest of working environments. Furthermore, they were specifically built to effectively process high gluten dough. All components and materials are top quality. Every member of our team takes pride in ensuring that our clients receive the very best in quality and construction, close attention is paid to mechanical as well as aesthetic detail.

TECHNICAL DATA SPIRAL DOUGH MIXERS	MIXER MODELS															
	CG/200KG FLOOR		CG/100KG FLOOR		CG/130KG FLOOR		CG/160KG		CG/200KG		CG/250KG		CG/300KG		CG/450KG	
	METRIC	IMPERIAL	METRIC	IMPERIAL	METRIC	IMPERIAL	METRIC	IMPERIAL	METRIC	IMPERIAL	METRIC	IMPERIAL	METRIC	IMPERIAL	METRIC	IMPERIAL
FLOOR MODEL OPERATIONAL DIMENSIONS (W x D x H)	86.4 x 94 x 121.9 (cm)	34 x 37 x 48 (in)	88.9 x 134.6 x 134.6 (cm)	35 x 53 x 53 (in)	91.4 x 127 x 139.7 (cm)	36 x 50 x 55 (in)	96.5 x 137.2 x 139.7 (cm)	38 x 54 x 55 (in)	96.5 x 137.2 x 139.7 (cm)	38 x 54 x 55 (in)	109.2 x 175.3 x 154.9 (cm)	43 x 69 x 61 (in)	109.2 x 175.3 x 154.9 (cm)	43 x 69 x 61 (in)	N/A	
HOIST MODEL OPERATIONAL DIMENSIONS	SEE CHART															
FLOOR MODEL SHIPPING DIMENSIONS (W x D x H)	105 x 155 x 155 (cm)	41 x 61 x 61 (in)	105 x 155 x 155 (cm)	41 x 61 x 61 (in)	105 x 155 x 155 (cm)	41 x 61 x 61 (in)	105 x 155 x 155 (cm)	41 x 61 x 61 (in)	105 x 155 x 155 (cm)	41 x 61 x 61 (in)	127 x 191 x 168 (cm)	50 x 75 x 66 (in)	127 x 191 x 168 (cm)	50 x 75 x 66 (in)	N/A	
HOIST MODEL SHIPPING DIMENSIONS (W x D x H-LOW (H-HIGH))	N/A		N/A		N/A		191 x 229 x 204 (cm)	75 x 90 x 80 (in)	191 x 229 x 204 (cm)	75 x 90 x 80 (in)	191 x 229 x 204 (cm)	75 x 90 x 80 (in)	191 x 229 x 204 (cm)	75 x 90 x 80 (in)	216 x 265 x 216 (cm)	85 x 104 x 85 (in)
SHIPPING WEIGHT FIXED BOWL (HOIST)	425 (kg)	935 (lbs)	445 (kg)	979 (lbs)	916 (kg)	2016 (lbs)	916(1550) (kg)	2016(3410) (lbs)	925(1600) (kg)	2035(3520) (lbs)	1410(1859) (kg)	3102(4090) (lbs)	1430(1880) (kg)	3146(4136) (lbs)	3337 (kg)	7350 (lbs)
BOWL DIAMETER	560 (mm)	22 (in)	700 (mm)	27.5 (in)	813 (mm)	32 (in)	915 (mm)	36 (in)	915 (mm)	36 (in)	1067 (mm)	42 (in)	1067 (mm)	42 (in)	1245 (mm)	49 (in)
FLOUR CAPACITY	33 (kg)	73 (lbs)	66 (kg)	145 (lbs)	86 (kg)	189 (lbs)	106 (kg)	233 (lbs)	133 (kg)	293 (lbs)	166 (kg)	366 (lbs)	200 (kg)	441 (lbs)	300 (kg)	661 (lbs)
FINISHED DOUGH CAPACITY (Based upon 50% moisture content)	51 (kg)	113 (lbs)	100 (kg)	220 (lbs)	130 (kg)	286 (lbs)	160 (kg)	353 (lbs)	200 (kg)	440 (lbs)	250 (kg)	551 (lbs)	300 (kg)	661 (lbs)	450 (kg)	991 (lbs)
POWER RATINGS	2.63 (kw)	3.5 (hp)	6.75 (kw)	9 (hp)	8.63 (kw)	11.5 (hp)	8.63 (kw)	11.5 (hp)	11.63 (kw)	15.5 (hp)	17.25 (kw)	23 (hp)	17.25 (kw)	23 (hp)	32.25 (kw)	43 (hp)
AMPERAGE @ 220V, 1 PHASE	38		N/A													
AMPERAGE @ 208V, 3 PHASE	14		29		38		38		40		65		65		N/A	
AMPERAGE @ 380V, 3 PHASE	8		16		21		21		22		36		36		N/A	
AMPERAGE @ 460V, 3 PHASE	7		15		19		19		20		33		33		90	
AMPERAGE @ 575V, 3 PHASE	6		11		14		14		15		24		24		72	
Amperages are for floor model mixers. Hoist model amperages available upon request.																
STANDARD OPTIONS	208/3/60 VOLTAGE TWO SPEED OPERATION STAINLESS WIRE GRILL PAINTED FINISH ANALOG CONTROL PANEL															
OPTIONS	OTHER VOLTAGE AVAILABLE UPON REQUEST PAINT COLOURS (WHITE, CHARCOAL, STAINLESS) STAINLESS ENCLOSED COVER WITH PISTON ASSIST DIGITAL CONTROL PANEL PLC CONTROL PANEL INFRARED TEMPERATURE SENSOR DOUGH TEMPERATURE PROBE SINGLE SPEED OPERATION VARIABLE SPEED (PLC PANEL ONLY) HEAVY DUTY SPIRAL ARM CENTRAL BAR STAINLESS STEEL PADDLE MIXER MOUNTED UPON HOIST LOW HOIST HIGH HOIST															

\* BASED UPON NO LESS THAN 50% LIQUID CONTENT, STANDARD VOLTAGE SUPPLIED IS 208-3-60, OTHER VOLTAGES ARE AVAILABLE UPON REQUEST.

All Data Not Binding. G. Cinelli - Esperia Corporation® reserves the right to effect improvements and modifications as necessary without prior notification.