

# ROTOR and ROLLER ROTATING RACK OVEN



An example of rotating rack oven ROTOR. The model of the picture is ROTOR 68.



An example of rotating rack oven ROLLER. The model of the picture is ROLLER 68.

The oven with rotating rack is a completely stainless steel oven with a unique backing chamber, demountable at any time, which installation requires short time. It is suited for backing different types of bread and other backing products, whether small or middle size.

The oven functions both with liquid fuels and with gas ones, by using appropriate burners. Its particular construction concept reduces the energy consumption.

The oven with rotating rack has a perfect thermic isolation. No toxic materials are employed, particularly asbestos.

In this oven the product to be baked is put on trays with dimensions suitable to the oven, the trays are placed on a trolley which will be inserted in the baking chamber. The loaded trolley rotates, while it is hanging from a special hook, and it is enveloped in a warm airflow. The functioning principle consists of transmitting heat to the food.



The advantages of this system are due to the fact that the rotating engine of the trolley is located on the top of the baking chamber, while the downer part is free, making easier all cleaning and maintenance operations.

The air is heated in a proper heatexchanger with a heat resistant surface that allows a big thermal exchange. The air heating is due to

transmission of heat from combustion products to the air getting in contact with the warm surface of the exchanger. The heated air is distributed through a fan in the baking chamber. The exhausted air returns to the heatexchanger to begin another cycle. The combustion give the heat, trough the heatexchanger, to the crossing air. The hot air is blew into the baking chamber from a fan, while this air gets cold, it returns in to the heatexchanger. The introduction and removing of the rack in the baking chamber are made possible by plastic and heat resistant wheels, the rack is inserted in a hooking unit; by this way the user has only to push slightly the rack into the chamber.

The machine complies with the latest CE regulations.

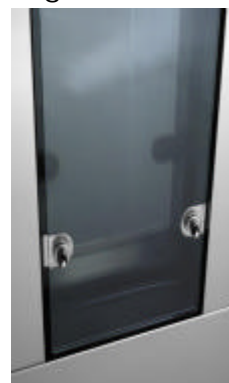

## LIST OF THE PRINCIPAL COMPONENTS

**BAKING CHAMBER.** This is the central part of the oven. It is all built in stainless steel. The different thickness, the particular folding system and the special combination of its parts optimise the functioning and cut down the loss of heat

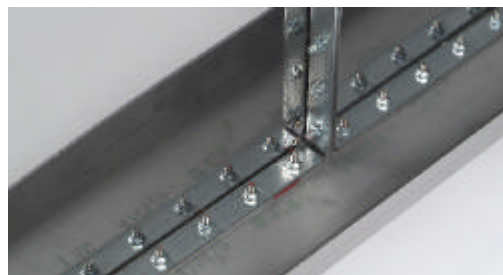

**HEATEXCHANGER.** This is the part of the oven that allows to the combustion gas to heat the air that gets in touch with the baking product. It is situated in the back part of the oven (ROTOTR) and the burner is installed in the bottom, or in the lateral part (ROLLER) and - in this case - the burner is installed in the front part.

It is built in heat resistant stainless steel and steel pipes in considerable number (30 pipes) in order to increase the surface of thermal exchange.

The combustion gases accomplish a long path inside the exchanger until the chimney exit (provided with an antiburst discharge and an security thermostat) and heat the air that goes through the exchanger externally. The path of the air is due to a ventilator that is situated on the

exchanger and that send the air into the baking chamber. It is a surface-exchanger where there isn't contact between combustion gases and the air that - after heating - get in touch with the baking product.

**VAPORIZER.** It produces the required steam and introduces it in the baking chamber.

It consists of "U" iron elements, over posed and canted alternatively to the left and right, so that the water, introduced in several points by means of pipes, flows downward.

These elements are heated at high temperature, producing therefore the water vaporization.

For their efficiency is necessary to keep clean from calcareous deposit.

Under the iron elements there is a small basin for receiving and expelling the surplus water.

The vaporizer is placed into the baking chamber behind its protection panel.

stopping.



**VENTILATOR FOR THE AIR CIRCULATION.** The ventilator allows the circulation of the hot air in the oven; it is installed above the heat exchanger with the suction point mounted on a collector communicating with the baking chamber. It is a centrifugal type ventilator with the motor directly connected to the impeller shaft. The motor has a power of about kW 1.1 for the ventilator model 330, kW 2,2 for the ventilator model 330 M. Both motors have one speed 1400 r.p.m., but it is possible to have the speed variator in optional.

**GEAR MOTOR FOR ROTATION OF THE TROLLEY.** These mechanisms generate the rotation of the trolley inside the baking chamber.

It consists of two worm gear reducer couplet by means of a connecting bell that allows a high reduction rate. The reducers kinematics consists of an endless screw and a rim. The frame is made in high resistance iron and aluminium.

The total transmission rate is 400:1 with an 0.18 kW and one speed motor. The gear motor is provided with a controlled safety friction clutch so that by low couple there is the immediate.

**CONNTROL PANEL.** The oven is provided with a control board very easy user impact, showing by mean of ideograms all functions. It has a double thermostats, timers, switches and emergency stop key.

On request the oven is available with the digital and programmable panel.



**BURNER.** It is an essential part of the oven as it produces the heat necessary for the baking. It is installed in the back left part of the oven, at the bottom (back chamber-oven - ROTOR) or in the front part (lateral chamber-oven - ROLLER).

Any problem of the burner may cause a bad functioning of the oven and, sometimes, may reduce its lifetime.

The burners used in the rotating rack ovens can be adapted according to the employed fuels: gas oil, methane gas and L.P.G. (BASSANINA ovens can working also with electric power).

The installation and starting of the burner, as well as the further maintenance operations, have to be carried out by skilled personnel, preferably authorized by the manufacturer of the burner.

**ELECTRIC BOARD.** The oven is provided with an electric board of the box type, with a key lock door. The protection is IP 54 type. The box is in sheet steel metal and contains the wiring of the electric devices.



## PROTECTION AND SAFETY DEVICES

**SAFETY THERMOSTAT:** this device guards against overcoming of the temperature inside the oven over the 300 °C, the thermostat switches off automatically the voltage of the burner and stops any burner functions.

**MICROSWITCH:** the door is connected with micro switch. By opening of the door interferes the micro switch and it stops immediately the rotation of the trolley and the ventilator, and it turns on the steam extractor.

**STEAM EXTRACTOR:** it is an extractor installed above the extractor hood that operates by opening the door during the operation of oven's unloading.

**INSIDE DOOR HANDLE:** it is installed on the door inside the baking chamber. It avoids that the operator, for any reason, remains closet inside the same baking chamber.

**FRICTION CLUTCH OF THE GEAR MOTOR:** friction of the gear motor that permits the stop by low couple.

**OVERAPRESSURE BLOCK:** it has been installed above the combustion chamber, in the fumes pipe, to reduce quickly the pressure inside the combustion chamber.

If the pressure increase over the calibration value, the block opens discharging upstream, in safety conditions for the operator, resetting the correct pressure inside the combustion chamber; at this point the block close automatically.

**STEAM BREATHER:** the steam breather is an opening situated in the bottom and inside of the baking chamber. This, through a pipeline; is connected with the steam extractor hood. When in the baking chamber the steam production reaches a limit value, this breather let go out the exceeding quantity.

## EC DECLARATION

The Declaration is submitted to the customer together with the machine.

## MANUAL

The instructions manual for use and maintenance is furnished in English, Italian or French language.

## PACKAGE

The oven is delivered:

- fully assembled;
  - partially assembled (semi assembled in one piece);
  - fully disassembled with components in wooden crates with following dimensions in cm. :
- |                  |                                     |
|------------------|-------------------------------------|
| 115x225x225      | model 50x70;                        |
| 145x225x225      | model 60x80;                        |
| 160x225x225      | model 80x80, 80x90, 60x100, 80x100; |
| 115x225x225x2box | model 80x120.                       |



## TECHNICAL FEATURES

### MODEL ROTOR

MODEL	TRAYS	DIMENSIONS TRAYS	HOURLY CAPACITY INDICATIVE	DIMENSIONS OVEN			THERMIC POWER	POWER	ELECTRIC ABSORB	WEIGHT
				A mm	B mm	H mm				
	n	cm	kg/h				kw	kcal/h	kw	kg
<b>57</b>	15/18	40x60 50x70	85	1239	1618.5	2068	53	45000	1,7	1250
<b>68</b>	15/18	60x80	125	1440	1930	2220	68	58000	2	1430
<b>88</b>	15/18	80x80	170	1630	2140	2220	70	60000	2.5	1700
<b>89</b>	15/18	80x90	190	1630	2140	2220	70	60000	2.5	1700
<b>610</b>	15/18	60x100	160	1630	2140	2220	70	60000	2.5	1700
<b>810</b>	15/18	80x100	210	1820	2460	2500	75	65000	3.8	1900
<b>812</b>	15/18	2x(60x80) 120x80	250	2000	3000	2600	128	110000	3.8	2100



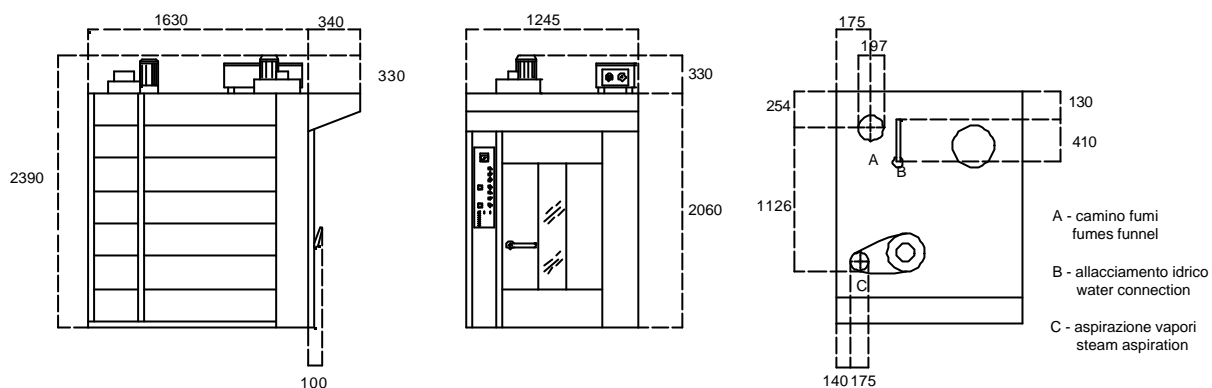

ROTOR mod. 57

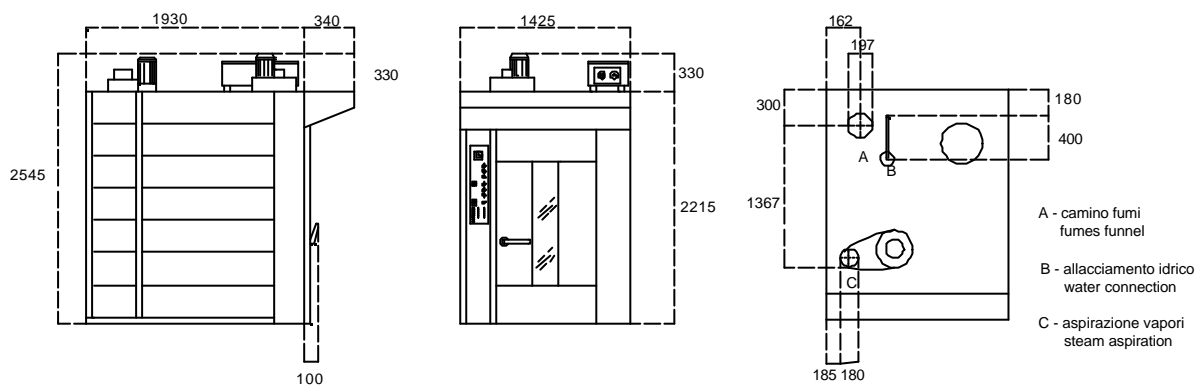

ROTOR mod. 68

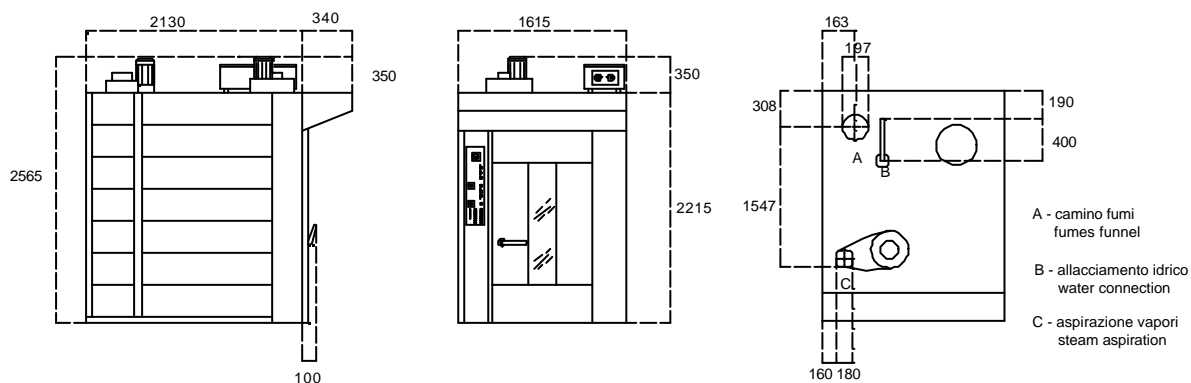

ROTOR mod. 88-89-610

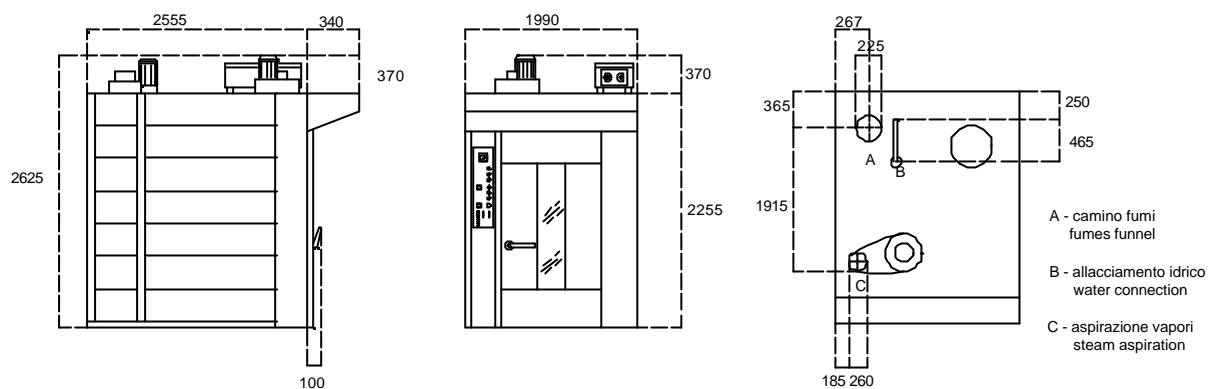

ROTOR mod. 812

## MODEL ROLLER

MODEL	TRAYS	DIMENSIONS TRAYS	HOURLY CAPACITY INDICATIVE	DIMENSIONS OVEN			THERMIC POWER	POWER	ELECTRIC ABSORB	WEIGHT
	n	cm	kg/h	A mm	B mm	H mm	kw	kcal/h	kw	kg
68	15/18	60x80	125	1910	1550	2220	68	58000	2	1550
88	15/18	80x80	170	2110	1750	2220	70	60000	2.5	1760
89	15/18	80x90	190	2110	1750	2220	70	60000	2.5	1760
610	15/18	60x100	160	2110	1750	2220	70	60000	2.5	1760

\* 1KW = 860 kcal/h    1000 kcal/h = 1.163 KW

## CONNECTION

**HYDRAULIC:** the connection is necessary for the vaporizer of the oven and must be of a minimum diameter of 12 mm and provide filtered water. The outline connection is ½ inc. The water pressure reaching the vaporizer is between 1 and 3.0 bar.

**STEAM EXHAUST TO THE DRAUGHT HOOD:** the exit diameter is 18 cm. (26 cm for the model 812). In the coupling area with the exterior piping (this must have a min. section of 0.035 m<sup>2</sup> it is better to install a box with dimensions of mm 400 x 500 x 400. The piping of steam exhaust must be slightly inclined to avoid the condensate return in the oven.

**EVACUATION OF THE COMBUSTION PRODUCTS:** the exit diameter is 20 cm. (23 cm for the model 812). It is necessary to consider that - in order to obtain a good functioning of the plant - on the base of the chimney there must be a depression within 0.1 ? 0.2 mbar. If possible avoid installing curves in the piping. If chimney and piping are outside the building, it is good standard to cover them with heat insulator materials to obtain a good draught also in the cold season and to avoid vapour condensations.

**ELECTRICAL CONNECTION:** verify that the voltage of the electric line to the electric box corresponds to the voltage required in the electrical diagram and on the label inside the box. Normally and if here isn't any different request, the connection is 3 phases + neutral, 400 voltage and 50 Hz.



## FUELS

The oven is functioning with a burner using following fuels: (see the manual of the burner enclosed to the present manual):

- DIESEL
- GAS METHAN
- LPG (LIQUEY PETROL GAS)

TYPE OF FUEL	TYPE OF BURNER	BOOST PRESSION Mbar	LOWER HEATING POWER
DIESEL	S	12	11.5 kW/kg
GAS METHAN (G20)	S	12 ? 14	10 kW/m <sup>3</sup> <sub>n</sub>
L. PETROL GAS -GPL (G30)	S	12 ? 14	13 kW/m <sup>3</sup> <sub>n</sub>

S = BLOWN BURNER

OVEN MODEL	BURNER MODEL DIESEL	BURNER BRAND	NOZZLE	KW min-max	Kg/h min-max
57	40 F 5	RIELLO	0.75x 60°	30-60	2.5-5
68	40 F 10	RIELLO	1.50x 60°	54-107	4.5-9
88	40 F 10	RIELLO	1.75x 60°	54-107	4.5-9
89	40 F 10	RIELLO	1.75x 60°	54-107	4.5-9
610	40 F 10	RIELLO	1.75x 60°	54-107	4.5-9
810	40 F 10	RIELLO	1.75x 60°	54-107	4.5-9
812	40 F 20	RIELLO	2.50x 60°	95-202	8-17

OVEN MODEL	BURNER MODEL GAS	BURNER BRAND	KW min-max	Kcal/h min-max
57	40 FS 5	RIELLO	23-58	20000-50000
68	40 FS 8	RIELLO	46-93	40000-80000
88	40 FS 8	RIELLO	46-93	40000-80000
89	40 FS 8	RIELLO	46-93	40000-80000
610	40 FS 8	RIELLO	46-93	40000-80000
810	40 FS 8	RIELLO	46-93	40000-80000
812	40 FS 15	RIELLO	81-175	70000-150500

**ATTENTION:** the ovens can have or are changed into electric power.

OVEN MODEL	ELECTRIC	KW Max on starting	KW Max on working	A (ampere)
57	E	(16X2400W) 38.4	(8X2400W) 19.2	61.5
68	E	(18X3000W) 54	(9X3000W) 27	84
88	E	(18X3400W) 61.2	(9X3400W) 30.6	101
89	E	(18X3400W) 61.2	(9X3400W) 30.6	101
610	E	(18X3400W) 61.2	(9X3400W) 30.6	101