

SOMERSET

MODEL CDR-2000S, WITH SYNTHETIC ROLLERS

MODEL CDR-2000, WITH HARD CHROME PLATED ROLLERS.

FEATURES:

- Safety sensors for automatic shutoff
- Compact design, ideal for use in limited space
- Sanitary, heavy duty, all stainless steel welded construction
- Spring loaded scrapers readily removable for easy cleaning
- Simple handle adjustments for exact uniform dough thickness
- Ergonomic design for easy operation
- Large hopper accepts large pieces of dough
- Convenient side operation
- Maintenance free drive mechanism
- Drive mechanism isolated from roller area
- Choice of synthetic or hard chrome plated rollers
- Safe...simple...easy to operate...easy to clean

DIMENSIONS:

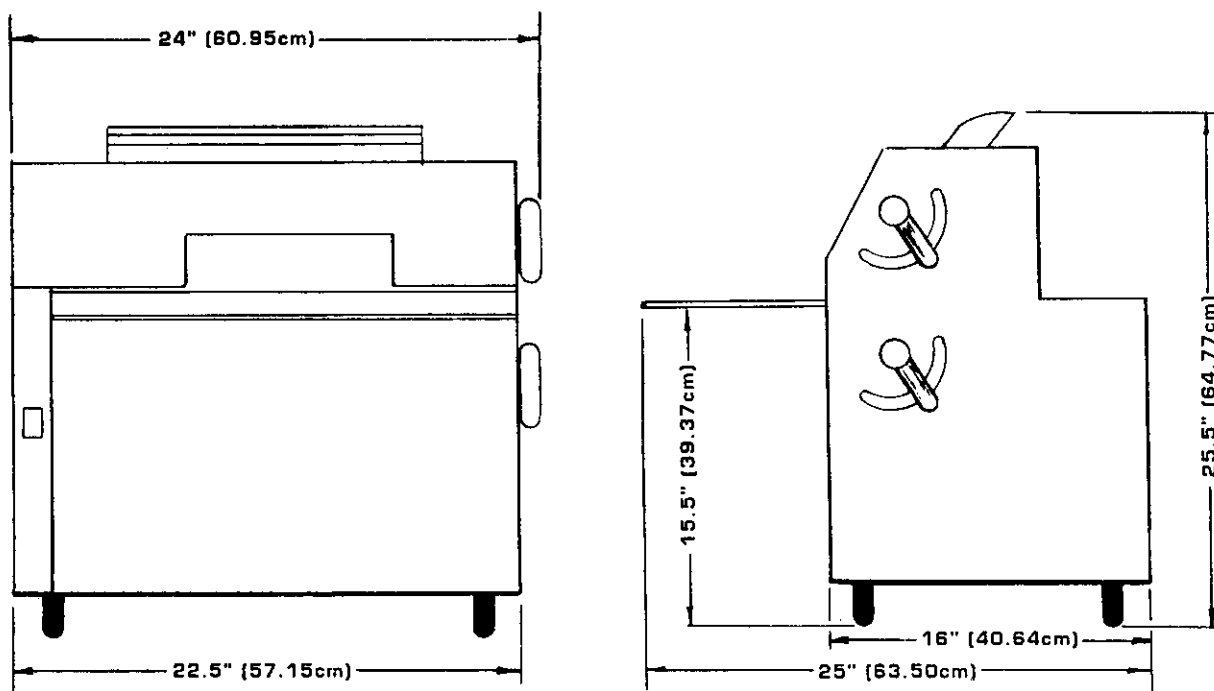

SPECIFICATIONS:

ROLLERS: 3.5" (8.89cm) Dia. by 20" (50.80 cm.) Length.

SCRAPERS: Synthetic, Spring Loaded, Removable.

BEARINGS: Sealed Ball Bearings, Permanently Lubricated.

GEAR MOTOR: Heavy Duty 3/4 HP Maintenance Free.
Single Phase, 115V, 60Hz or 220V, 50Hz.

FINISHING: All Stainless Steel.

LEGS: 4" Adjustable, Sanitary Stainless Steel.

SHIPPING WEIGHT: 218 lbs (98.88 kgs).