

COUNTER TOP

SELF-SERVE NON-REFRIGERATED BAKERY DISPLAY

OPTIONAL ACCESSORIES:

- * Reflective Ends
- * Reflective Rear Doors
- * Front Swing Doors Incorporating Acrylic Lift-up Doors

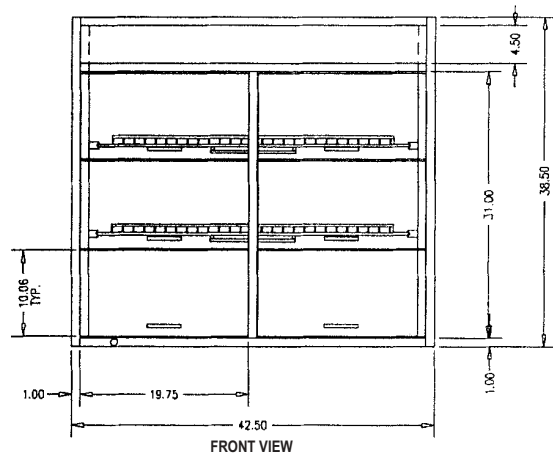
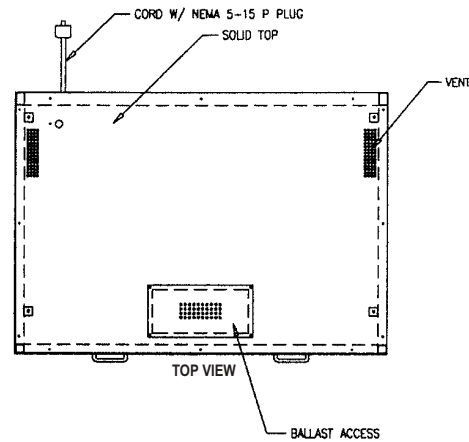
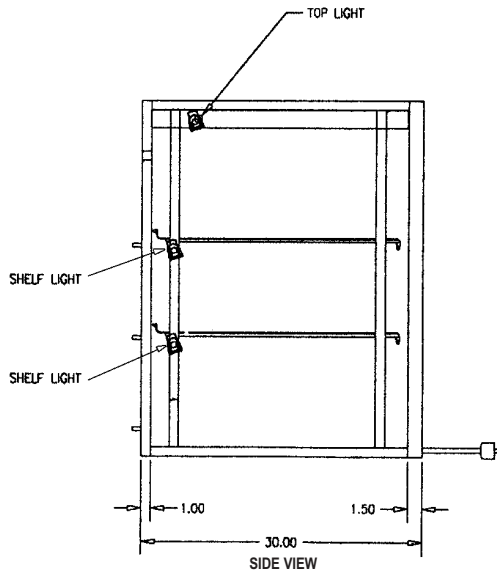

SPECIFICATIONS:

Model	Dimensions L W H	Shipping Weight (lbs)	Capacity (Bakery Pans)	Power 120/60/1
CT-6	42 1/2" x 30" x 38 1/2"	375	6 (18" x 26")	2.0 AMPS
CT-9	60 1/4" x 30" x 38 1/2"	450	9 (18" x 26")	2.0 AMPS
CT-12	80" x 30" x 38 1/2"	748	12 (18" x 26")	2.0 AMPS



- Due to continuing engineering improvements, specifications are subject to change without notice.

Look to Federal for Innovative Merchandising



a Standex company

Federal Industries
A Standex Company
215 Federal Avenue
Belleville WI 53508-0290
Phone: 800-356-4206
Fax: 608-424-3234
Email: geninfo@federalind.com
Web Site: www.federalind.com