

BK40 BAGEL KETTLE



- UNIQUE SPUN BOWL DESIGN ALLOWS HEAT TRANSFER ON BOWL SIDES, AS WELL AS BOTTOM, FOR FASTER BOILING AND GREATER EFFICIENCY AND GAS SAVINGS OF HUNDREDS OF DOLLARS ANNUALLY.
- CONVENIENT, FRONT MOUNTED CONTROLS ALLOW OPERATOR GREATER CONTROL COMPARED TO ANY OTHER BAGEL KETTLE.
- SPUN BOWL DESIGN IS EASIER TO CLEAN THAN ANY OTHER KETTLE. THIS DESIGN IS BISSC APPROVED AND MEETS NSF CONSTRUCTION STANDARDS. NO OTHER TRADITIONAL BAGEL KETTLE IS SANITATION APPROVED.
- NO ELECTRIC REQUIREMENTS AND AN IMPROVED, AGA CERTIFIED VENT SYSTEM WILL SAVE HUNDREDS OF DOLLARS IN CONSTRUCTION AND INSTALLATION COSTS.
- QUALITY, HIGH EFFICIENCY BURNER IS ADJUSTABLE FROM 80,000 TO 180,000 BTU'S PER HOUR.

THE NEW DAVRIK BK-40 BAGEL KETTLE HAS BEEN PERFECTED BY BAGEL BAKERS, FOR BAGEL BAKERS. UNDER DEVELOPMENT FOR OVER 2 YEARS, IT HAS ALL THE FEATURES AND REFINEMENTS NEEDED IN TODAY'S BAGEL BAKERY.

WHETHER YOU ARE MAKING THE TRADITIONAL EAST COAST BAGEL OR THE SOFT AND CHEWY WEST COAST BAGEL, YOU WILL BOIL PERFECT BAGELS EVERY TIME.

FOR SPEED, CONVENIENCE, GAS EFFICIENCY, AND SANITATION, THERE IS NO COMPARISON. THE ONLY FULLY APPROVED AMERICAN GAS ASSOCIATION (AGA) AND BAKERY SANITATION (BISSC) CERTIFIED BAGEL KETTLE AVAILABLE TODAY!



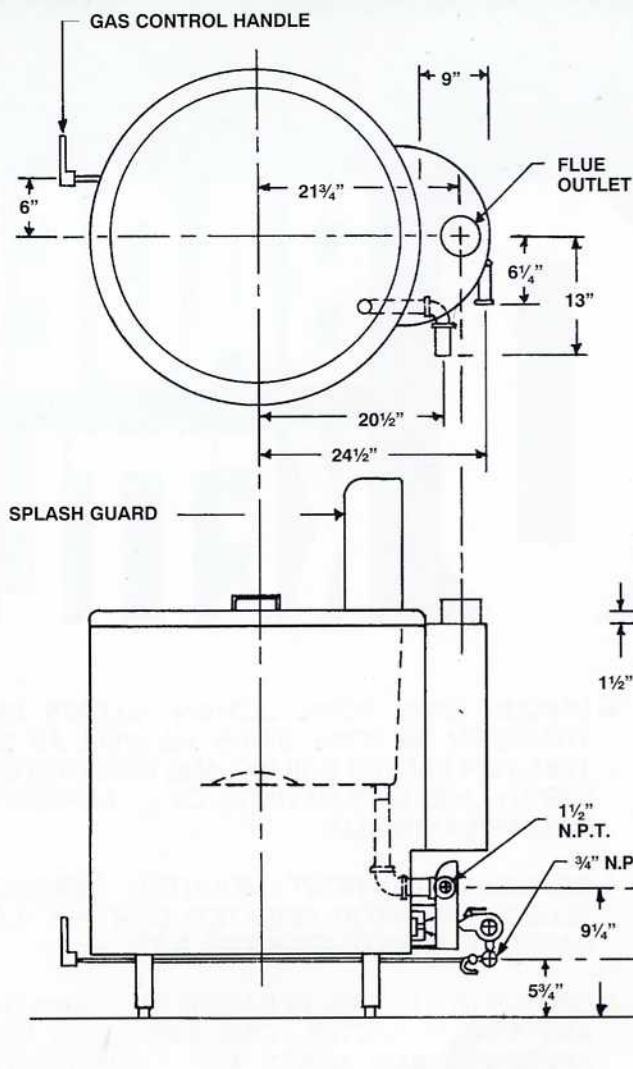

MODEL BK-40 UTILITY REQUIREMENTS

GAS: 3/4" PIPE, 180,000 BTU/HOUR MAX. @ 5" TO 7" W.C.
DRAIN: 1-1/2" OUTLET, MUST DRAIN TO FLOOR SINK
VENT: 6" DIA. OUTLET FROM INTEGRAL VENT BOX

ASK FOR DAVRIK OPTIONAL VENTING/PLUMBING ACCESSORY PACKAGE

VENTING REQUIREMENTS

THE DAVRIK BK-40 BAGEL KETTLE IS SUPPLIED WITH A 6" VERTICAL COLLAR CONNECTION FOR THE FLUE OUTLET. A HEAVY WALL STAINLESS STEEL DRAFT DIVERTER IS INCLUDED. KETTLE IS TO BE INSTALLED UNDER AN APPROVED EXHAUST HOOD; THE FLUE VENT STACK IS TO VENT INTO THE CANOPY HOOD ONLY. DO NOT EXHAUST THE FLUE STACK INDEPENDENTLY. NOTE: ALL VENTING DETAILS MUST BE IN COMPLIANCE WITH LOCAL CODES.

OPTIONAL

PLUMBING AND VENTING PACKAGE, DESIGNED TO ASSIST THE INSTALLATION, THIS PACKAGE INCLUDES A KETTLE FILL FAUCET WITH MOUNTING BRACKET, 1-1/2" HIGH QUALITY BRASS DRAIN VALVE, AND 5 FOOT SECTION OF VENT PIPE WITH VENT PIPE SAFETY INSULATION WRAP.

INSTALLATION

THE BK-40 IS SHIPPED FULLY ASSEMBLED FOR EASY INSTALLATION. ALL COMPONENTS ARE FACTORY TESTED. ADJUSTABLE LEGS ARE PROVIDED FOR LEVELING ON UNEVEN FLOORS. CAUTION: TO REDUCE THE RISK OF FIRE, THE KETTLE IS TO BE MOUNTED ON NON-COMBUSTIBLE FLOORING THAT EXTENDS AT LEAST 12 INCHES BEYOND THE EQUIPMENT ON ALL SIDES. AT LEAST 12 INCHES OF HORIZONTAL SPACING MUST BE MAINTAINED BETWEEN THE KETTLE AND ANY COMBUSTIBLE WALLS, STRUCTURES OR MATERIALS. IMPORTANT: DO NOT ROUTE ANY UTILITIES (WIRING OR PLUMBING) WITHIN 12 INCHES OF THE KETTLE.

SHIPPING

CRATE DIMENSIONS: 41" X 49" X 49"
 SHIPPING WEIGHT: 425 LBS. CLASS 85



1714 S. California Ave.
 Monrovia, CA 91016
 Ph: (818) 358-1343
 Fax (818) 358-1613

DEALER INFO: