

HIGH VOLUME DUAL ZONE CASE

OPTIONAL ACCESSORIES:

- * Special Base Finish
- * Glass Shelves
- * Rear Wrapping Board
- * Cord & Plug (Self-Contained Models Only)
- * Remote Refrigeration
- * Black, Gold, or Chrome Wire Shelves
- * Reflective Ends
- * White or Mirrored Interior Ends With Laminated Exterior
- * Reflective Rear Doors
- * Casters/Cord & Plug Included (Self-Contained Models Only)
- * Legs
- * Top Cutting Board, White
- * Package Shelf
- * Light Below Package Shelf
- * Front Glass and Rear Door Locks

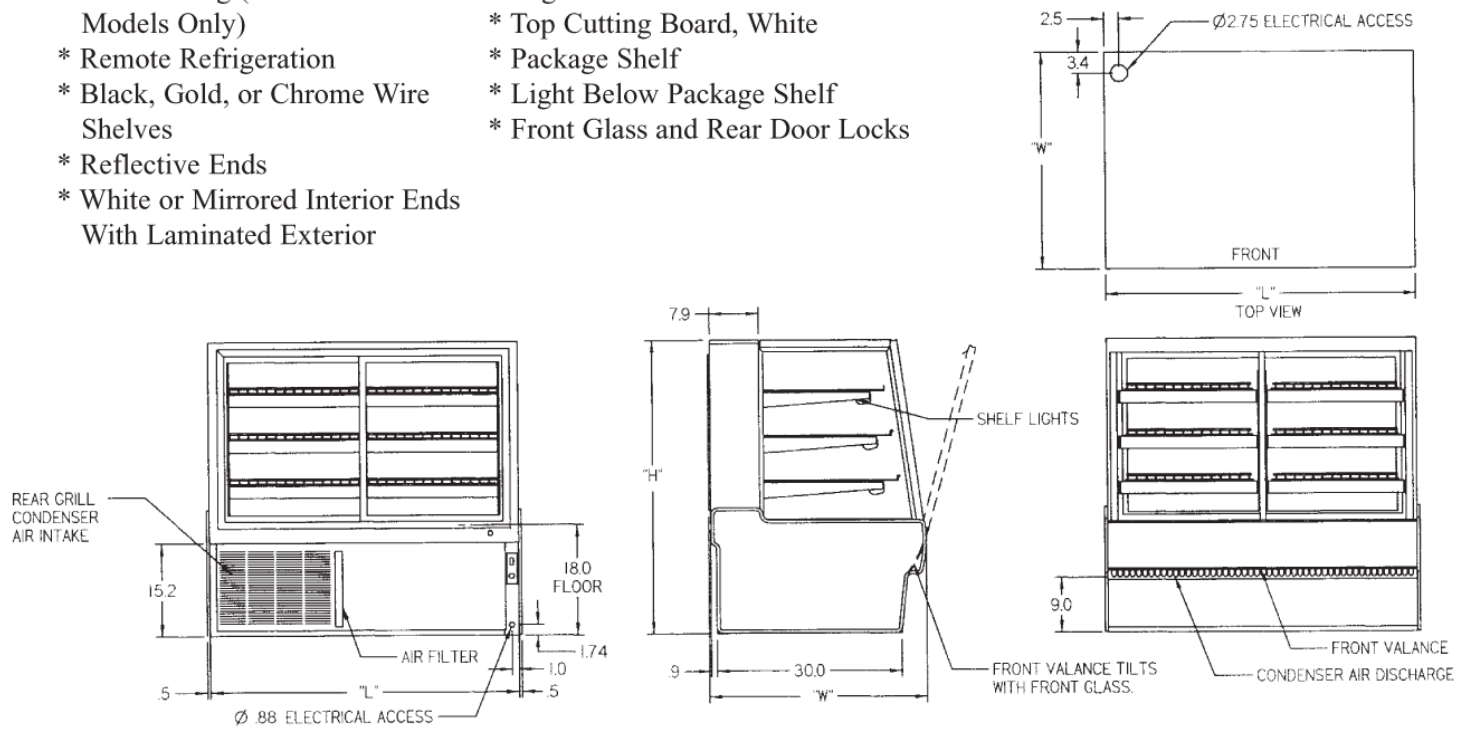

SPECIFICATIONS:

Model	Dimensions			Shipping Weight (lbs)	Self-Contained 120/60/1	Remote 120/60/1
	L	W	H			
SGR5042DZ	50.3"	35.31"	42"	688	1/3 HP - 8.0 AMPS	2.5 AMPS
SGR5048DZ	50.3"	35.31"	48"	730	1/3 HP - 8.0 AMPS	2.5 AMPS
SGR5942DZ	59.13"	35.31"	42"	735	1/3 HP - 9.0 AMPS	3.0 AMPS
SGR5948DZ	59.13"	35.31"	48"	765	1/3 HP - 9.0 AMPS	3.0 AMPS
SGR7742DZ	77.13"	35.31"	42"	890	1/3 HP - 9.0 AMPS	3.0 AMPS
SGR7748DZ	77.13"	35.31"	48"	930	1/3 HP - 9.0 AMPS	3.0 AMPS

- Refrigerated cases are designed to operate in a maximum environment of 75° ambient and 55% relative humidity.
- Due to continuing engineering improvements, specifications are subject to change without notice.

