

MARKET SERIES

NON-REFRIGERATED BAKERY CASE

OPTIONAL ACCESSORIES:

- * Special Case Height (50" or 52")
- * Front Bumper Rail (Black, White, Green, Gray)
- * Reflective End Glass
- * Decorative End Panel (Black, White, Green, Gray)
- * Top Service Shelf
- * Accent Base Light
- * Promolux Lighting

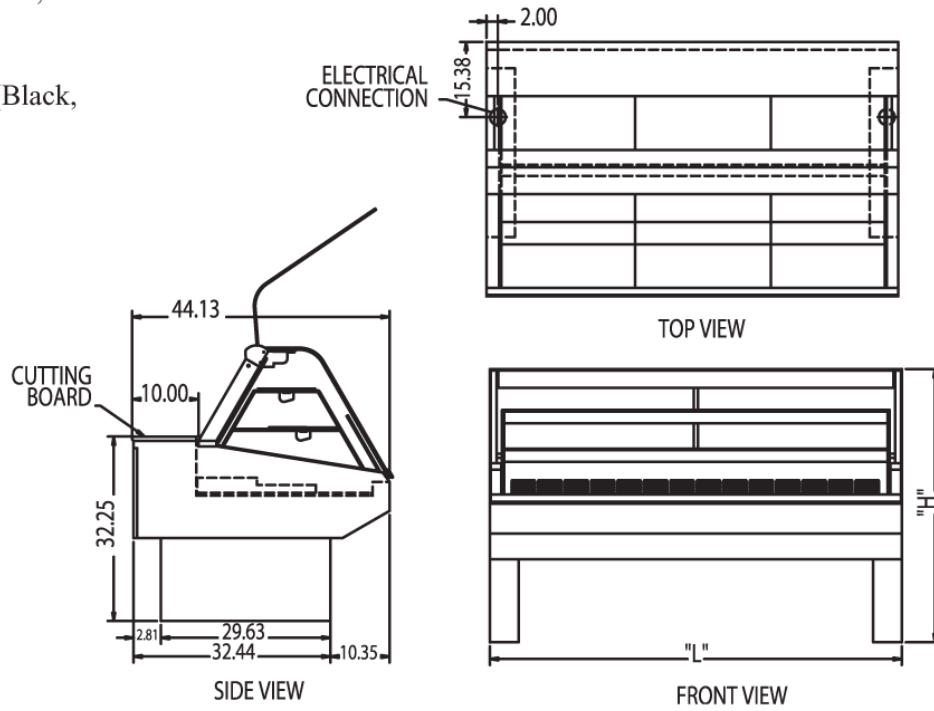

SPECIFICATIONS:

Model	*Dimensions L W H	Approx. Shipping Weight (lbs)	**Remote 120/60/1
SQ-3B	36" x 44 1/8" x 32 1/4"	590	3 AMPS
SQ-4B	48" x 44 1/8" x 32 1/4"	745	3 AMPS
SQ-5B	60" x 44 1/8" x 32 1/4"	895	3 AMPS
SQ-6B	72" x 44 1/8" x 32 1/4"	935	3 AMPS
SQ-8B	96" x 44 1/8" x 32 1/4"	1,035	3 AMPS

- *Without decorative end panel.
- **Plus general receptacle 120V, 15 AMP. (2nd circuit required.)
- **When ordering, specify case line-up and pedestal or panel design.**
- Due to continuing engineering improvements, specifications are subject to change without notice.



a Standex company